

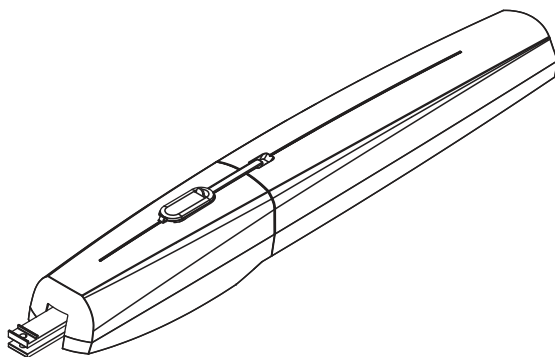

**Gear motor for swing gates
AXI series**

FA01007-EN



AXI20DGS - AXI25DGS

INSTALLATION OPERATION AND MAINTENANCE MANUAL

EN English

===== Hand these instructions to the end user =====

MANUALLY RELEASING THE GEAR MOTOR

△ **Manually releasing the gate may cause an uncontrolled movement of the gate due to possible mechanical anomalies or unbalancing.**

RELEASE (figure B)

- Open the hatch, fit the trilobe key and turn it
- Take out the release tab.

LOCKING (figure C)

Pull the tab down, turn the key clockwise to return it to its position and close the hatch.

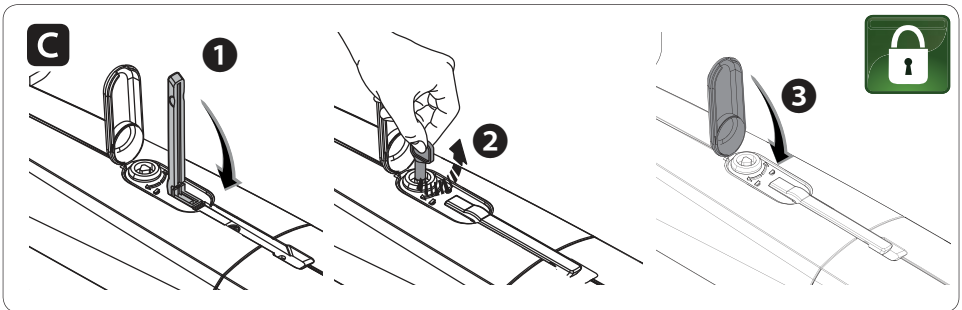
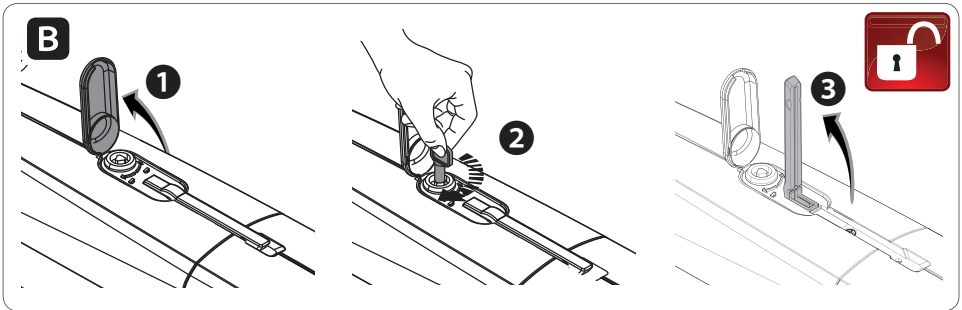

WHAT TO DO IF ...

ISSUES	POSSIBLE CAUSES	POSSIBLE FIXES
It neither opens nor closes	<ul style="list-style-type: none">• Power supply is missing• The gear motor is stuck• The transmitter emits a weak signal or no signal• Control buttons or selectors stuck	<ul style="list-style-type: none">• Check main power supply• Lock the gearmotor• Replace the batteries • Check integrity of devices and/or of electrical cables
The gate opens but does not close	<ul style="list-style-type: none">• The photocells are working	<ul style="list-style-type: none">• Check that there are no obstructions in the photocells' area of operation

△ **If the problem cannot be solved by following the fixes in the table or if any malfunctions, anomalies, noises, vibrations or suspicious and unexpected behavior is experienced on the system, call for qualified assistance.**

Fabbricante / Manufacturer / Hersteller / Fabricant / Fabricante / Fabricante
/ Wytwórca / Fabrikant

Came S.p.a.

Indirizzo / address / adresse / adresse / dirección / endereço / adres / adres
Via Martiri della Libertà 15 - 31030 Dossin di Casier, Treviso - Italy



DICHIARO CHE IL MOTORIDUTTORE PER CANCELLI A BATTENTE / DECLARES THAT THE GEARMOTOR FOR SWING GATE / ERKLÄRE DASS DIE TORÖFFNER FÜR FLÜGELTÖRE / DECLARE QUE LE MOTOREDUCTEUR POUR PORTAILS A BATTANTS / DECLARA QUE LAS MOTORREDUCTOR PARA PUERTAS BATTIENTES / DECLARA QUE AS MOTORREDUCTOR PARA PORTOES A BATENTE / OSWADCZA ZE SIŁOWNIKÓW DO BRAM SKRZYDŁOWYCH / VERKLAART DAT DE MOTOR VOOR DRAAIHEKKEN

AXI20DGS AXI25DGS

E' CONFORME ALLE DISPOSIZIONI DELLE SEGUENTI DIRETTIVE / IT COMPLIES WITH THE PROVISIONS OF THE FOLLOWING DIRECTIVES / DEN VORGABEN DER FOLGENDEN RICHTLINIEN ENTSPRECHEN / IL EST CONFORME AUX DISPOSITIONS DES DIRECTIVES SUIVANTES / CUMPLIEN CON LAS DISPOSICIONES DE LAS SIGUIENTES DIRECTIVAS / ESTÁ DE ACORDO COM AS DISPOSICÕES DAS SEGUINTEIS DIRECTIVAS / SA ZGODNE Z POSTANOVENIAMI NASTEPUJĄCYCH DYREKTYW EUROPEJSKICH / VOLDÖEN AAN DE VOORSCHRIFTEN VAN DE VOLGENDE RICHTLINIEN:

- COMPATIBILITA' ELETTROMAGNETICA / ELECTROMAGNETIC COMPATIBILITY / ELEKTROMAGNETISCHE VERTRÄGLICHKEIT / COMPATIBILITE ÉLECTROMAGNETIQUE / COMPATIBILIDAD ELECTROMAGNÉTICA / COMPATIBILIDADE ELETROMAGNÉTICA / KOMPATYBILNOŚCI ELEKTROMAGNETYCZNEJ / ELEKTROMAGNETISCHE COMPATIBILITEIT : 2014/30/EU.

Riferimento norme armonizzate ed altre norme tecniche / Refer to European regulations and other technical regulations / Harmonisierete Bezugsnormen und andere technische Vorgaben / Referéncia de normas harmonizadas e outras normas técnicas / Referéncia normas armonizadas e outras normas técnicas / Referéncia de normas harmonizadas a outras normas técnicas / Odnosno norme ujednotčene i inne norme tehnične / Geharmoniseerde en andere technische normen waarnaar is verwezen

EN 61000-6-2:2005
EN 61000-6-3:2007+A1:2011
EN 61000-6-4:2007+A1:2011

RISPETTA I REQUISITI ESSENZIALI APPLICATI / MEET THE APPLICABLE ESSENTIAL REQUIREMENTS / DEN WESENTLIJCHEN AANGEWANDTEN ANFOORDERINGEN ENTSPRECHEN / RESPECTENT LES CONDITIONS REQUISES NECESSAIRES APPLIQUÉES / CUMPLEN CON LOS REQUISITOS ESSENCIALES APLICADOS / RESPETEM O REQUISITOS ESSENCIAIS APLICADOS / SPECIFIKACJA PODSTAWOWE WYMAGANIA WYRLNIKI / VOLDÖEN AAN DE TOEPASBARE MINIMUM EISEN:

1.1.3; 1.1.5; 1.2.1; 1.2.2; 1.3.2; 1.3.7; 1.3.8.1; 1.4.1; 1.4.2; 1.5.1; 1.5.6; 1.5.8; 1.5.9; 1.5.9; 1.5.13; 1.6.1; 1.6.3; 1.6.4; 1.7.1; 1.7.2; 1.7.4

PERSONA AUTORIZZATA A COSTITUIRE LA DOCUMENTAZIONE TECNICA PERTINENTE / PERSON AUTHORISED TO COMPILE THE RELEVANT TECHNICAL DOCUMENTATION / PERSON DIE BEVOLMÄCHTIGT IST, DIE RELEVANTEN TECHNISCHEN UNTERLAGEN ZUSAMMENZUSTELLEN / DOCUMENTATION TECHNIQUE SPECIFIQUE D'AUTORISATION A CONSTITUER DE / PERSONA FACULTADA PARA ELABORAR LA DOCUMENTACION TECNICA PERTINENTE / PESSOA AUTORIZADA A CONSTITUIR A DOCUMENTAÇÃO TÉCNICA PERTINENTE / OSOBA UPLOWAZNIONA DO ZREDKOWANIWA DOKUMENTACJI TECHNICZNEJ / DEGENE DIE GEMOENTIGD IS DE RELEVANTE TECHNISCHE DOCUMENTEN SAMEN TE STELLEN.

CAME S.p.a.

La documentazione tecnica pertinente è stata compilata in conformità all'allegato VIB. / The pertinent technical documentation has been drawn up in compliance with attached document VIB. / Die relevante technische Dokumentation wurde entsprechend der Anlage VIB ausgestellt. / La documentación técnica específica a été remplie conformément à l'annexe IB / La documentación técnica pertinente ha sido redactada en cumplimiento con el anexo VIB. / A documentação técnica referente foi preenchida de acordo com o anexo VIB. / Odnosna dokumentacija tehnična zozastavljena zgodnje z zloženikom VIB. / De technische documentatie terzake is opgesteld in overeenstemming met de bijlage VIB.

CAME S.p.a. si impegna a trasmettere, in risposta a una richiesta adeguatamente motivata dalla autorità nazionale, informazioni pertinenti sulle quasi macchine, e / Came S.p.a., following a duly motivated request from the national authorities, undertakes to provide information related to the quasi machines, and / Die Firma Came S.p.A. verpflichtet sich auf eine angemessen motivierte Anfrage der staatlichen Behörden Informationen über die unvollständigen Maschinen, zu übermitteln, und / Came S.p.A. s'engage à transmettre, en réponse à une demande bien fondée de la part des autorités nationales, les renseignements relatifs aux quasi machines. / Came S.p.A. se compromette a transmitir, como respuesta a una solicitud adecuadamente fundada por parte de las autoridades nacionales, informaciones relacionadas con las cuasimáquinas. / Came S.p.A. compromete-se a transmitir, em resposta a uma solicitação motivada apropriadamente pelas autoridades nacionais, informações relacionadas com as cuasimáquinas. / Came S.p.A. compromete-se a transmitir, em resposta a uma solicitação motivada devidamente fundamentada pelas autoridades nacionais, informações relacionadas com as cuasimáquinas. / Came S.p.A. zobowiązuje się do udzielenia informacji dotyczących maszyn nieukończonych na odpowiednio uzasadnione prośbie, złożona przez kompetentne organy państwowe. / Came S.p.A., verbindt zich ertoe om op verzoek met name omkred verzoek van de nationale autoriteiten de relevante informatie voor de niet voltooid machine te verstrekken.

VIETA / FORBIDS / VERBIET / INTERDIT / PROHIBE / PROHIBE / ZABRANIA SIE / VERBIED

La messa in servizio finale della macchina finale in cui deve essere incorporata non è stata dichiarata conforme, se del caso alla 2006/42/CE, / completion of the above mentioned until such moment when the final machine into which they must be incorporated, has been declared compliant, if pertinent, to 2006/42/CE. / Die Inbetriebnahme bevor die „Endmaschine“ in die die unvollständige Maschine eingebaut wird, als konform erklärt wurde, gegebenenfalls gemäß der Richtlinie 2006/42/EU. / La mise en service tant que la machine finale dans laquelle elle doit être incorporée n'a pas été déclarée conforme, le cas échéant, à la norme 2006/42/CE. / In puesta en servicio hasta que la máquina final en la que será incorporada no haya sido declarada de conformidad de acuerdo a la 2006/42/CE. / A colocação em funcionamento, até que a máquina final, onde deva ser incorporada, não for declarada em conformidade, se de acordo com a 2006/42/CE. / Ustawienie urządzenia do czasu, kiedy maszyna, do której ma być wbudowana, nie zostanie oznaczone jako zgodna z wymogami dyrektywy 2006/42/WE. Jest taka procedura była konieczna, / deze in werking te stellen zolang de eindmachine waarn de niet voltooid machine moet worden ingebouwd in overeenstemming is verklaard, indien toepasselijk met de richtlijn 2006/42/EG.

Dossin di Casier (TV)
30 Novembre / November / November /
Novembre / Novembre / November /
Listopad / November 2017

Legale Rappresentante / Legal Representative / Gesetzlicher
Vertreter / Representant Legal / Representante Legal /
Representante Legal / Prawny Przedstawiciel / Juridische
Vertegenwoordiger

Paolo Menuzzo

Fascicolo tecnico a supporto / Supporting technical dossier / Unterstützungstechnische Dossier / soutien dossier technique / apoyo expediente técnico / apolár dossier técnico / wspieranie dokumentacji technicznej / ondersteunende technische dossier: 801MP-0030

Came S.p.a.

Via Martiri della Libertà, 15 - 31030 Dossin di Casier - Treviso - Italy - Tel. (+39) 0422 4940 - Fax (+39) 0422 4941
Info@came.it - www.came.com

Cap. Soc. 1.610.000,00 € - C.F. e P.I. 03481280265 - VAT IT 03481280265 - REA TV 275359 - Reg Imp. TV 03481280265

WARNING! Important safety instructions.



Follow all of these instructions. Improper installation can cause serious bodily harm.

Before continuing, also read the general precautions for users.

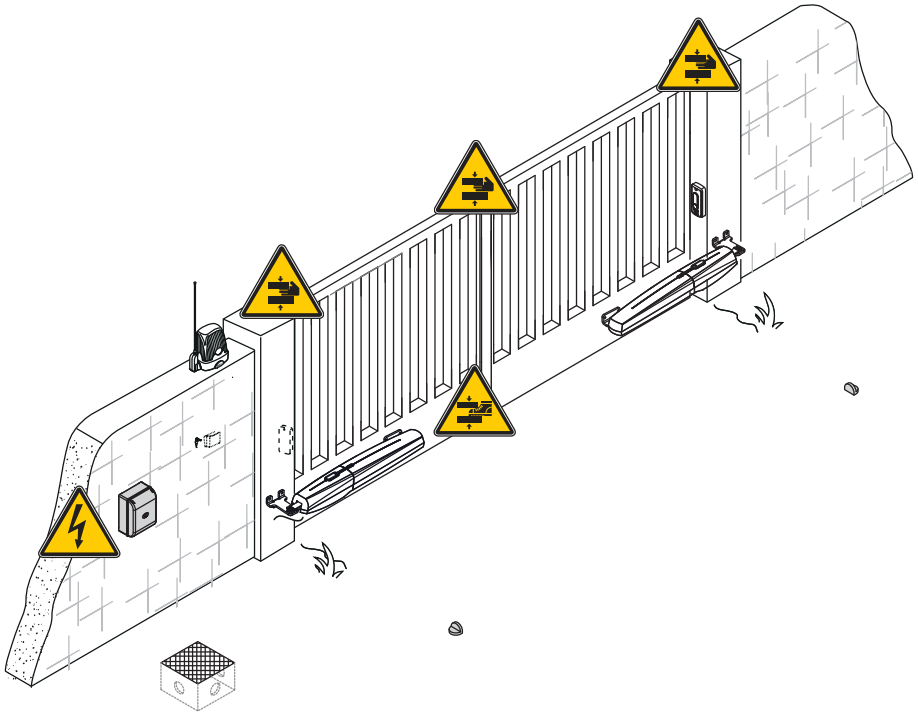

THIS PRODUCT MUST ONLY BE USED FOR ITS SPECIFICALLY INTENDED PURPOSE. ANY OTHER USE IS DANGEROUS. GAMES.P.A. IS NOT LIABLE FOR ANY DAMAGE CAUSED BY IMPROPER, WRONGFUL AND UNREASONABLE USE. • THIS MANUAL'S PRODUCT IS DEFINED BY MACHINERY DIRECTIVE 2006/42/CE AS "PARTLY-COMPLETED MACHINERY". QUASI-COMPLETED MACHINERY IS PARTLY-COMPLETED MACHINERY IS A SET THAT ALMOST CONSTITUTES A MACHINE, BUT WHICH, ALONE, CANNOT ENSURE A CLEARLY DEFINED APPLICATION. PARTLY-COMPLETED MACHINERY IS ONLY DESTINED TO BE INCORPORATED OR ASSEMBLED TO OTHER MACHINERY OR OTHER PARTLY-COMPLETED MACHINERY OR APPARATUSSES TO BUILD MACHINERY THAT IS REGULATED BY DIRECTIVE 2006/42/CE. THE FINAL INSTALLATION MUST BE COMPLIANT WITH EUROPEAN DIRECTIVE 2006/42/CE AND CURRENT EUROPEAN REFERENCE STANDARDS. GIVEN THESE CONSIDERATIONS, ALL PROCEDURES STATED IN THIS MANUAL MUST BE EXCLUSIVELY PERFORMED BY EXPERT, QUALIFIED STAFF. • THE MANUFACTURER DECLINES ANY LIABILITY FOR USING NON-ORIGINAL PRODUCTS; WHICH WOULD RESULT IN WARRANTY LOSS • KEEP THIS MANUAL INSIDE THE TECHNICAL FOLDER ALONG WITH THE MANUALS OF ALL THE OTHER DEVICES USED FOR YOUR AUTOMATION SYSTEM. • CHECK THAT THE TEMPERATURE RANGE SHOWN ON THE OPERATOR IS SUITABLE TO THE LOCATIONS WHERE IT WILL BE INSTALLED. • LAYING THE CABLES, INSTALLATION AND TESTING MUST FOLLOW STATE-OF-THE-ART PROCEDURES AS DICTATED BY REGULATIONS • IF THE POWER-SUPPLY CABLE IS DAMAGED, IT MUST BE IMMEDIATELY REPLACED BY THE MANUFACTURER OR BY AN AUTHORIZED TECHNICAL ASSISTANCE CENTER, OR IN ANY CASE, BY QUALIFIED STAFF, TO PREVENT ANY RISK • DURING ALL PHASES OF THE INSTALLATION MAKE SURE YOU HAVE CUT OFF THE MAINS POWER SOURCE. • THE OPERATOR CANNOT BE USED WITH GATES FITTED WITH PEDESTRIAN DOORS, UNLESS ITS OPERATION CAN BE ACTIVATED ONLY WHEN THE PEDESTRIAN DOOR IS IN SAFETY POSITION. • MAKE SURE THAT PEOPLE ARE NOT ENTRAPPED BETWEEN THE GATE'S MOVING AND FIXED PARTS DUE TO THE GATE'S MOVEMENT. BEFORE INSTALLING THE OPERATOR, CHECK THAT THE GATE IS IN PROPER MECHANICAL CONDITION, THAT IT IS PROPERLY BALANCED AND THAT IT PROPERLY CLOSSES: IF ANY OF THESE CONDITIONS ARE NOT MET, DO NOT CONTINUE BEFORE HAVING MET ALL SAFETY REQUIREMENTS. • MAKE SURE THAT OPENING AND CLOSING LIMITERS ARE FITTED • MAKE SURE THE OPERATOR IS INSTALLED ONTO A STURDY SURFACE THAT IS PROTECTED FROM ANY COLLISIONS • MAKE SURE THAT MECHANICAL STOPS ARE ALREADY INSTALLED • IF THE OPERATOR IS INSTALLED LOWER THAN 2.5 M FROM THE GROUND OR FROM ANY OTHER ACCESS LEVEL, FIT ANY PROTECTIONS AND SIGNS TO PREVENT HAZARDOUS SITUATIONS. • DO NOT FIT THE OPERATOR UPSIDE DOWN OR ONTO ELEMENTS THAT COULD YIELD TO ITS WEIGHT. IF NECESSARY, ADD REINFORCEMENTS TO THE FASTENING POINTS • DO NOT INSTALL DOOR OR GATE LEAVES ON TILTED SURFACES • CHECK THAT NO LAWN WATERING DEVICES SPRAY THE OPERATOR WITH WATER FROM THE BOTTOM UP. • ANY RESIDUAL RISKS MUST BE INDICATED CLEARLY WITH PROPER SIGNAGE AFFIXED IN VISIBLE AREAS. ALL OF WHICH MUST BE EXPLAINED TO END USERS. • SUITABLY SECTION OFF AND DEMARCATÉ THE ENTIRE INSTALLATION SITE TO PREVENT UNAUTHORIZED PERSONS FROM ENTERING THE AREA, ESPECIALLY MINORS AND CHILDREN. • AFFIX CAUTIONARY SIGNS, SUCH AS THE DOOR PLATE, THE GATE PLATE, WHEREVER NEEDED AND IN PLAIN SIGHT. • USE PROPER PROTECTIONS TO PREVENT MECHANICAL HAZARDS WHEN PEOPLE ARE LOITERING AROUND THE MACHINERY'S RANGE OF ACTION, FOR EXAMPLE AVOID CRUSHING OF FINGERS BETWEEN THE DRIVE SHAFT AND THE MECHANICAL STOPS, AVOID CRUSHING WHEN THE GATE IS OPENING • THE ELECTRICAL CABLES MUST RUN THROUGH THE CABLE GLANDS AND NOT TOUCH ANY PARTS THAT MAY OVERHEAT, SUCH AS THE MOTOR, TRANSFORMER, AND SO ON • SET UP A SUITABLE DUAL POLE CUT OFF DEVICE ALONG THE POWER SUPPLY THAT IS COMPLIANT WITH THE INSTALLATION RULES. IT SHOULD COMPLETELY CUT OFF THE POWER SUPPLY ACCORDING TO CATEGORY III SURCHARGE CONDITIONS • ALL OPENING CONTROLS MUST BE INSTALLED AT LEAST 1.85 M FROM THE PERIMETER OF THE GATE'S WORKING AREA, OR WHERE THEY CANNOT BE REACHED FROM OUTSIDE THE GATE. • ALL SWITCHES IN MAINTAINED ACTION MODE MUST BE POSITIONED SO THAT THE MOVING GATES LEAVES, THE TRANSIT AREAS AND VEHICLE THRU-WAYS ARE COMPLETELY VISIBLE, AND YET THE SWITCHES MUST BE ALSO AWAY FROM ANY MOVING PARTS • UNLESS THE ACTION IS KEY OPERATED, THE CONTROL DEVICES MUST BE FITTED AT, AT LEAST, 1.5 M FROM THE GROUND AND MUST NOT BE ACCESSIBLE TO THE PUBLIC. • TO PASS THE COLLISION FORCE TEST USE A SUITABLE SENSITIVE SAFETY-EDGE. INSTALL IT PROPERLY AND ADJUST AS NEEDED. • BEFORE HANDING OVER TO USERS, CHECK THAT THE SYSTEM IS COMPLIANT WITH THE 2006/42/CE UNIFORMED MACHINERY DIRECTIVE. MAKE SURE THE SETTINGS ON THE OPERATOR ARE ALL SUITABLE AND THAT ANY SAFETY AND PROTECTION DEVICES, AND ALSO THE MANUAL RELEASE, WORK PROPERLY. • AFFIX A PERMANENT TAG, THAT DESCRIBES HOW TO USE THE MANUAL RELEASE MECHANISM, CLOSE TO THE MECHANISM. • MAKE SURE TO HAND OVER TO THE END USER, ALL OPERATING MANUALS FOR THE PRODUCTS THAT MAKE UP THE FINAL MACHINERY.

- THE NEXT FIGURE SHOWS THE MAIN HAZARD POINTS FOR PEOPLE -



-  Danger of high voltage
-  Danger of hand entrapment
-  Danger of foot crushing

KEY

-  This symbol shows which parts to read carefully.
-  This symbol shows which parts describe safety issues
-  This symbol shows which parts to tell users about.

The measurements, unless otherwise stated, are in millimeters.

DESCRIPTION

Encoder-fitted irreversible gearmotor for swing gates.
Aluminium and ABS cover, worm screw based reduction system, crown and conical torque.

INTENDED USE

This gearmotor is designed to power and operate swing gates in private homes and apartment blocks.

 Any installation other than what is detailed in this manual is prohibited.

LIMITS TO USE

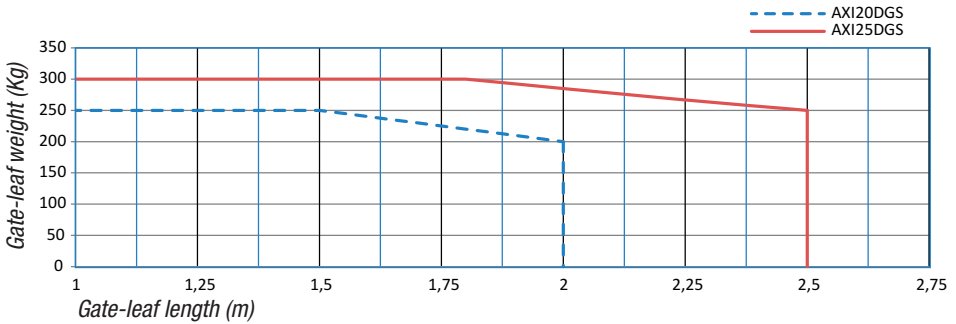

It is always advisable to fit an electric lock on swing gates. It makes for a more reliable closure.

DIMENSIONS

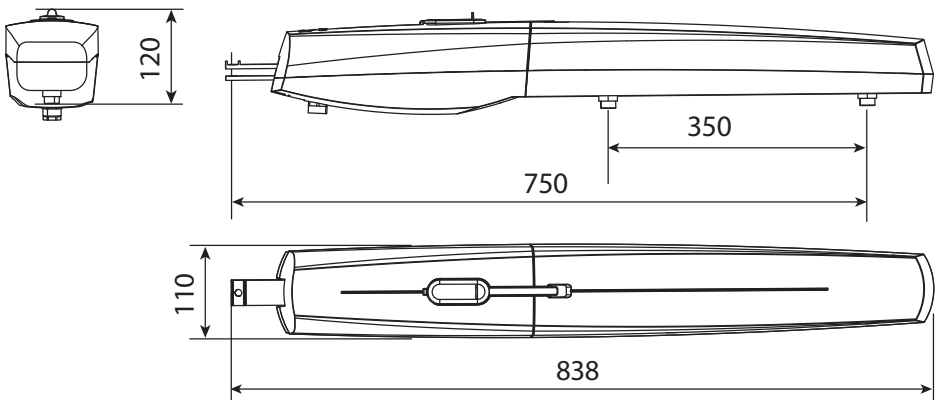

TECHNICAL DATA

Type	AXI20DGS	AXI25DGS
Protection rating (IP)		44
Control panel power supply (V - 50/60 Hz)		230 AC
Input voltage motor (V)		24 DC
Max draw (A)		5
Maximum power (W)		120
Duty cycle (%)		50
Opening time at 90° (s)		15*
Operating temperature (°C)		-20 to +55
Apparatus class		3
Reduction ration (i)		1/36
Thrust (N)		400 ÷ 2000
Weight (Kg)	5.5	6

* Smallest reference value with fastest travel and slowest slow-down speeds. The weight and type of door, the gate's state of wear-and-tear and the geography can all vary the value.

DESCRIPTION OF PARTS

1. Gear motor
2. Gate bracket and fastening screw
3. Post bracket and fastening screw
4. Bushing for post bracket
5. Release key
6. Cover 1
7. Cover 2

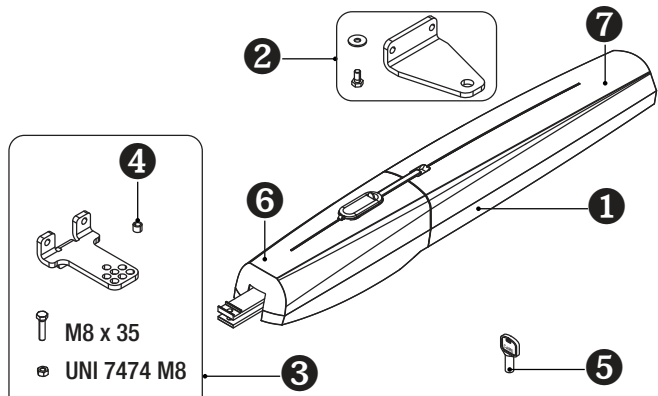

STANDARD INSTALLATION

1. Gear motor
2. Control panel
3. Transmitter
4. Key-switch selector
5. Flashing light
6. Photocells
7. Junction pit
8. Mechanical gate stops

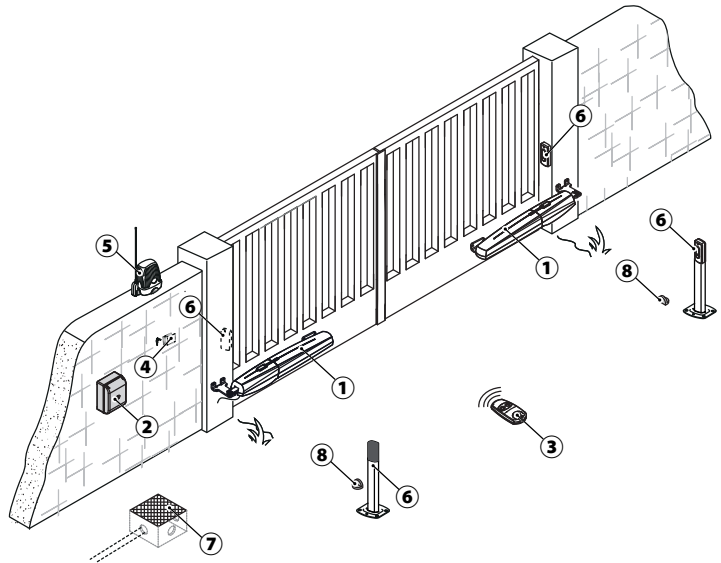

GENERAL INSTALLATION INDICATIONS

△ Only skilled, qualified staff must install this product.

PRELIMINARY CHECKS

△ Before beginning the installation, do the following:

- make sure there are opening and closing mechanical gate stops;
- make sure that the point where the gearmotor is fastened is protected from any impacts and that the surface is solid enough;
- set up suitable tubes and conduits for the electric cables to pass through, making sure they are protected from any mechanical damage.

CABLE TYPES AND MINIMUM SECTIONS

Connection	cable length	
	< 20 m	20 < 30 m
Input voltage for 230 V AC control board (1P+N+PE)	3G x 1.5 mm ²	3G x 2.5 mm ²
Signaling devices	2 x 0.5 mm ²	
Command and control devices	2 x 0.5 mm ²	
Safety devices (photocells)	(TX = 2 x 0.5 mm ²) (RX = 2 x 0.5 mm ²)	

📖 When operating at 230 V and outdoors, use H05RN-F-type cables that are 60245 IEC 57 (IEC) compliant; whereas indoors, use H05VV-F-type cables that are 60227 IEC 53 (IEC) compliant. For power supplies up to 48 V, you can use FROR 20-22 II-type cables that comply with EN 50267-2-1 (CEI).

📖 To connect the antenna, use the RG58 (we suggest up to 5 m).

📖 For paired connection and CRP, use a UTP CAT5-type cable (up to 1,000 m long).

📖 If cable lengths differ from those specified in the table, establish the cable sections depending on the actual power draw of the connected devices and according to the provisions of regulation CEI EN 60204-1.

📖 For multiple, sequential loads along the same line, the dimensions on the table need to be recalculated according to the actual power draw and distances. For connecting products that are not contemplated in this manual, see the literature accompanying said products

INSTALLATION

The following illustrations are mere examples in that the space for anchoring the operator and accessories varies depending on the installation area. It is up to the installer to find the most suitable solution.

CORRUGATED TUBE LAYING

Set up the junction boxes and corrugated tubes you will need to make connections coming from the junction pit. To connect the gearmotor we suggest a $\varnothing 60$ mm corrugated tube. Whereas for the accessories we suggest $\varnothing 25$ mm tubes.

The number of tubes depends on the type of system and the accessories you are going to fit.

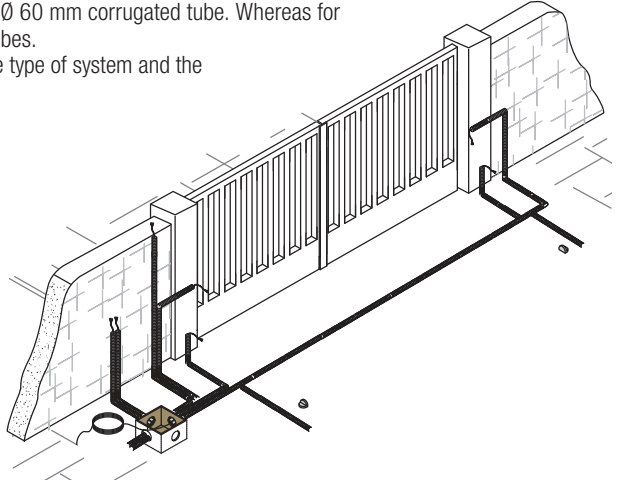

FASTENING THE BRACES

Establish the gate bracket fastening point and find the bracket's fastening point to the post, while respecting the quotas shown in the drawings and tables.

Opening (°)	A (mm)	B (mm)	C (mm)	E (mm)
90	130	110 - 170	0 - 60	750
115	150	110 - 160	0 - 50	750

△ The greater the gate leaf's opening angle, the greater the opening speed and the slower is the gearmotor's thrust. The smaller the gate leaf's opening angle, the slower the opening speed and the greater is the gearmotor's thrust.

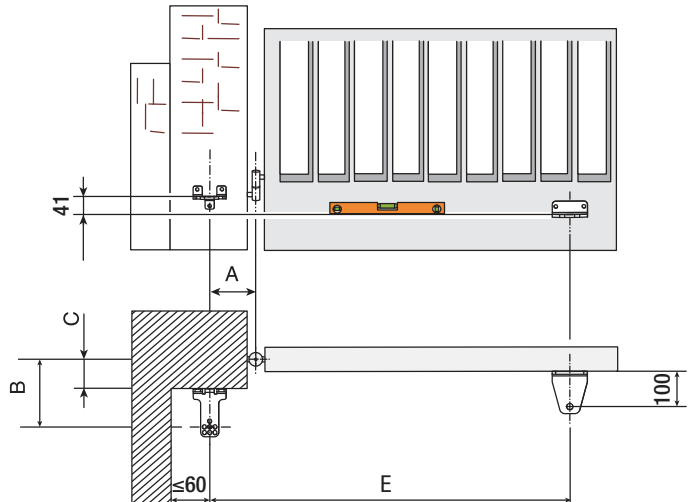

Fasten the bracket to the post **1** using suitable anchors and screws. If the post is made of metal, the bracket can be welded to it.

Note: the holes on the bracket are for further opening angle variations of the gate leaf.

Fasten or weld the bracket to the gate **2**.

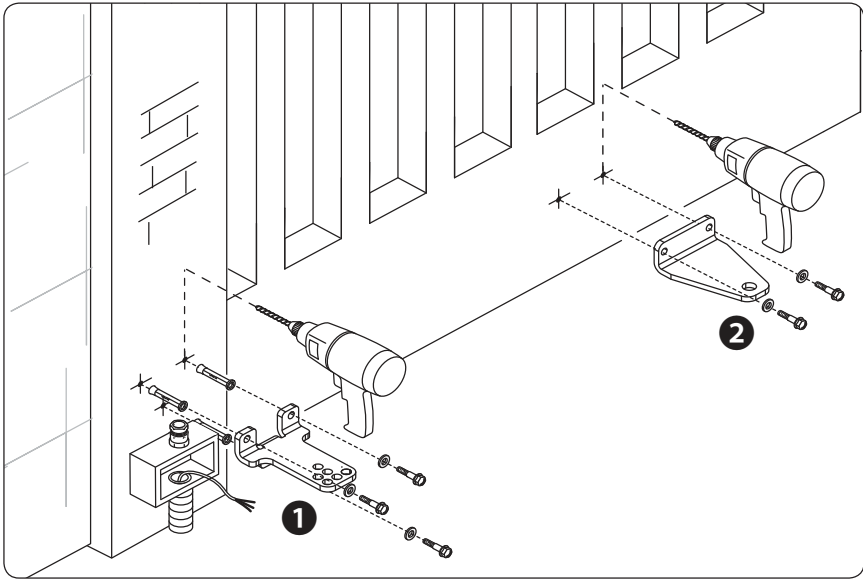

FASTENING THE GEARMOTOR

Lubricate the bushing **a** and fit it into one of the holes on the post bracket.

Fasten the joint to the post bracket **b** using the M8 x 35 bolt and UNI 7474 M8 nut.

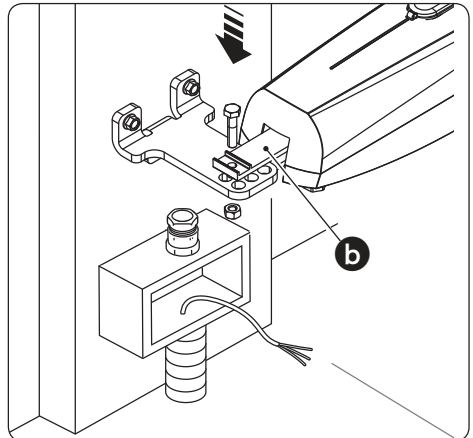
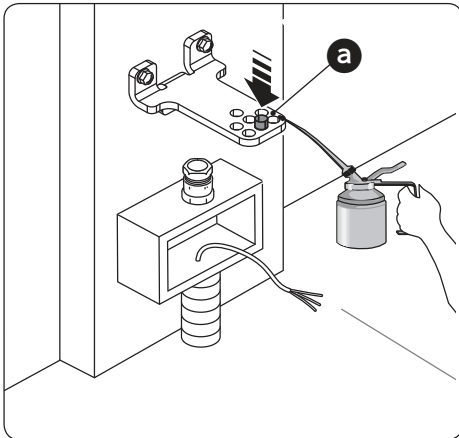

Open the gate leaf (the grub screws on the mechanical stops are loose) and fit the pin **a** into the gate bracket. Fasten using the UNI6593 washer \varnothing 10 and the supplied UNI 5739 M10 X 10 bolt **b** **c**.

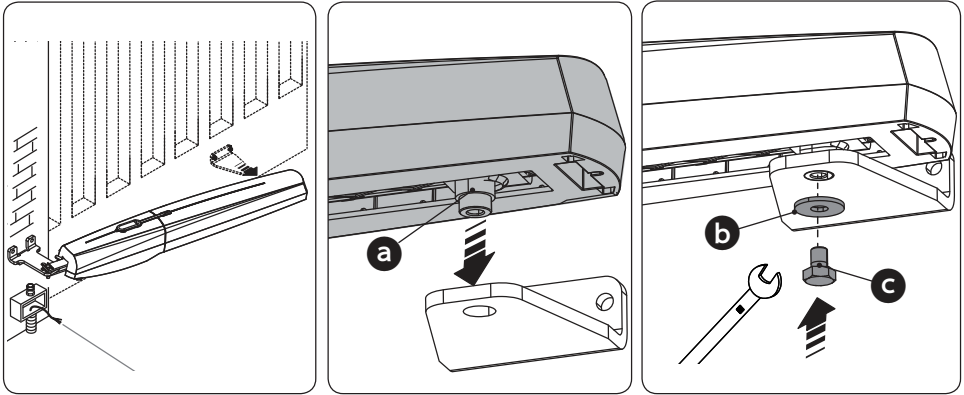

ESTABLISHING THE LIMIT-SWITCH POINTS

Before establishing the endstop points, you need to: release the gearmotor (see paragraph on manually releasing it) and remove covers 1 and 2 while carefully following the illustrations.

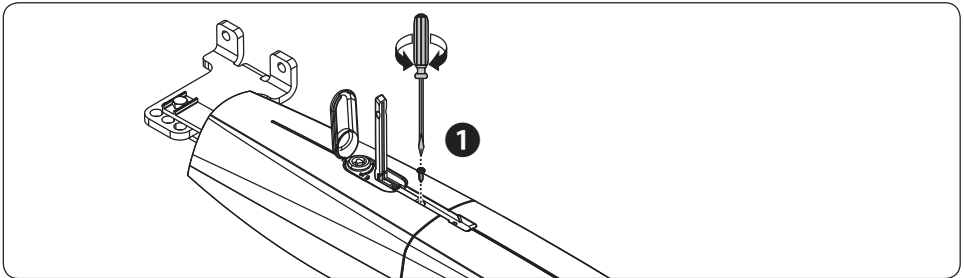

⚠ DO NOT REMOVE cover 1 without first sliding it.

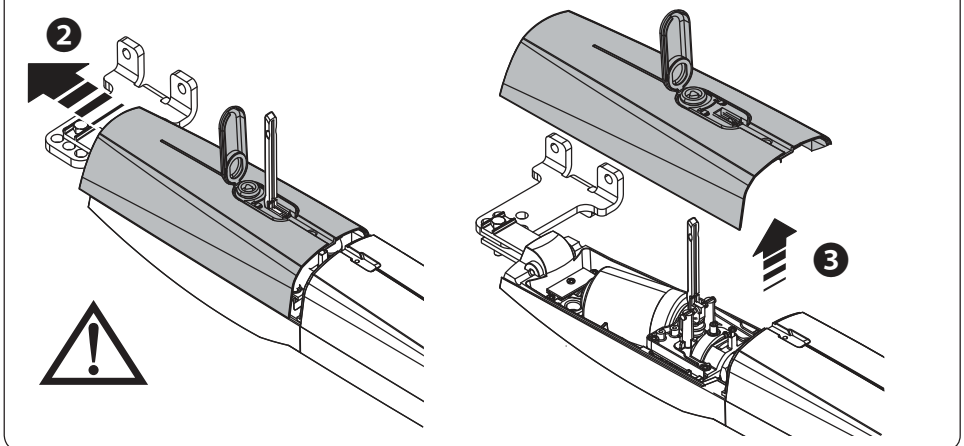

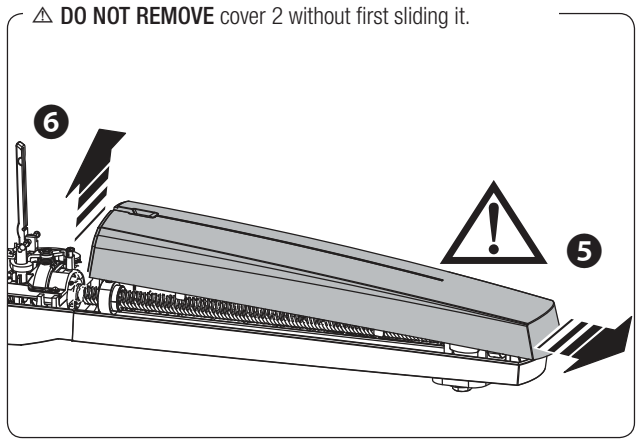
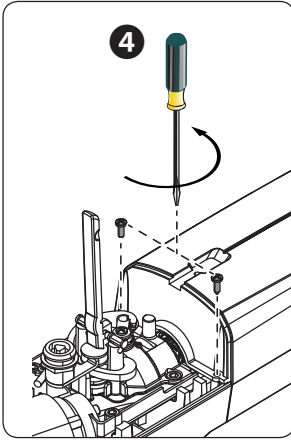

For opening

Reach the gate leaf opening point you want and take the mechanical stop to rest using the slide guide. Fasten the closing mechanical stop's grub screws **a**.

For closing

Close the gate leaf completely and rest it against the mechanical stop using the slide guide. Fasten the closing mechanical stop's grub screws **b**.

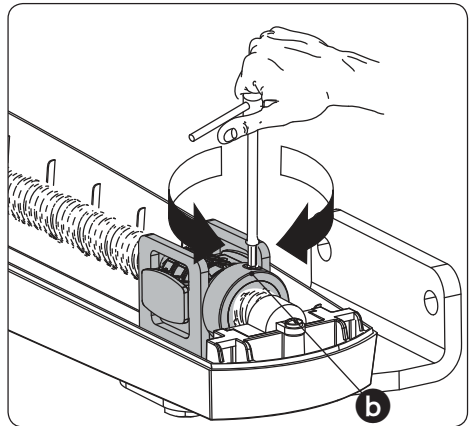
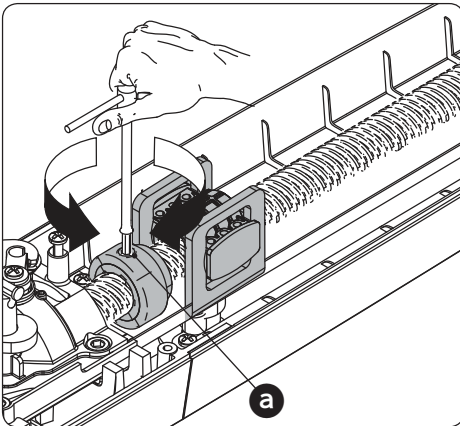

CONNECTIONS TO THE CONTROL PANEL

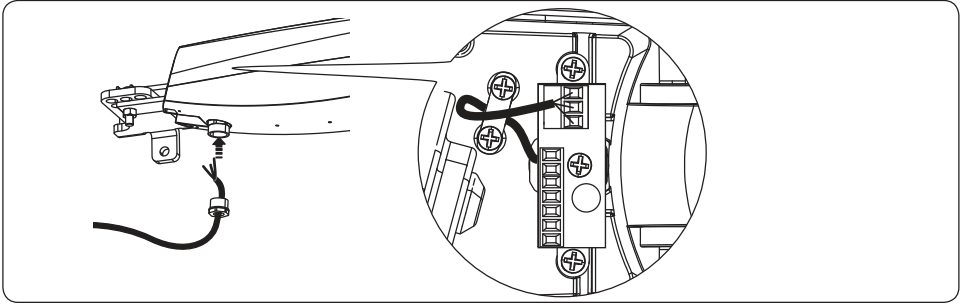

CONNECTING TWO GEARMOTORS

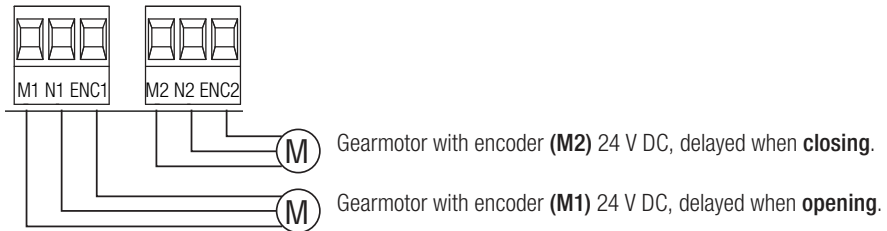

CONNECTING ONE GEARMOTOR



CONNECTION FOR OPENING OUTWARDS

△ Establish the quotas **A** and **B**.

Cut and fasten post bracket **a** by supplementing it with an additional bracket **b** (not issued).

Open the gate (max 90°), establish the quota **E** and establish the gate bracket fastening point. Fasten the bracket.

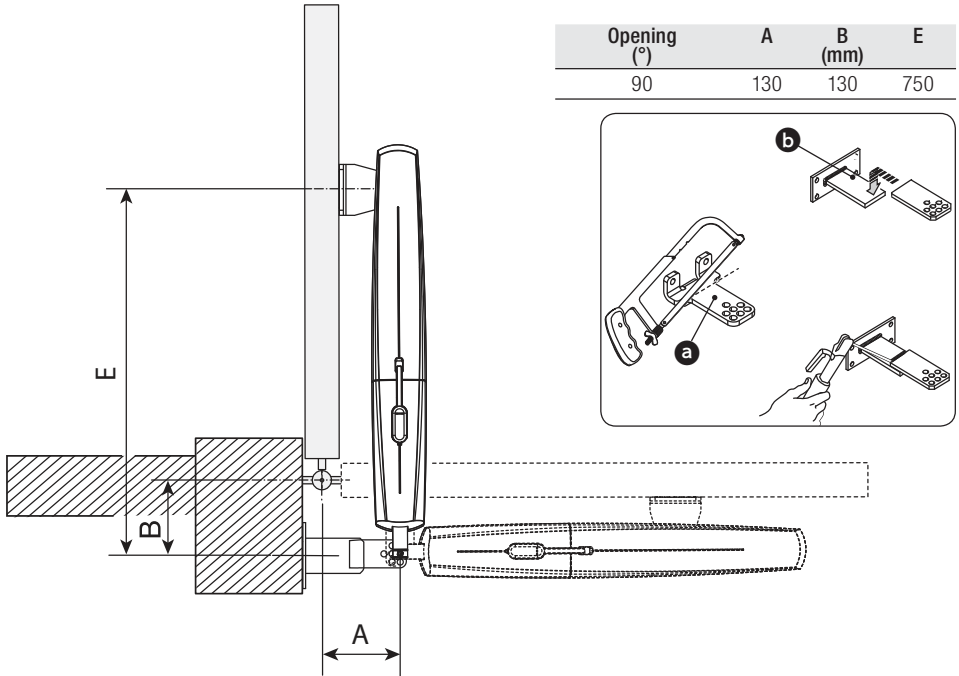

Opening (°)	A	B (mm)	E
90	130	130	750

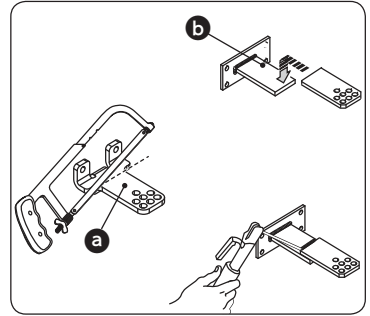

Make the necessary electrical connections as shown in the figure.

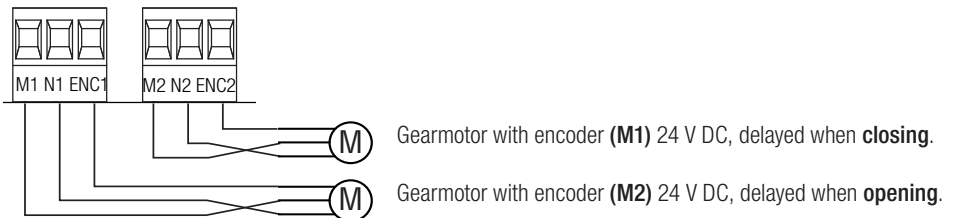

FINAL OPERATIONS

FASTENING THE COVERS

Once you have completed all electrical connections and commissioning, fit the covers as shown here

⚠ YOU MUST first slide the covers forward and then snap them down into place.

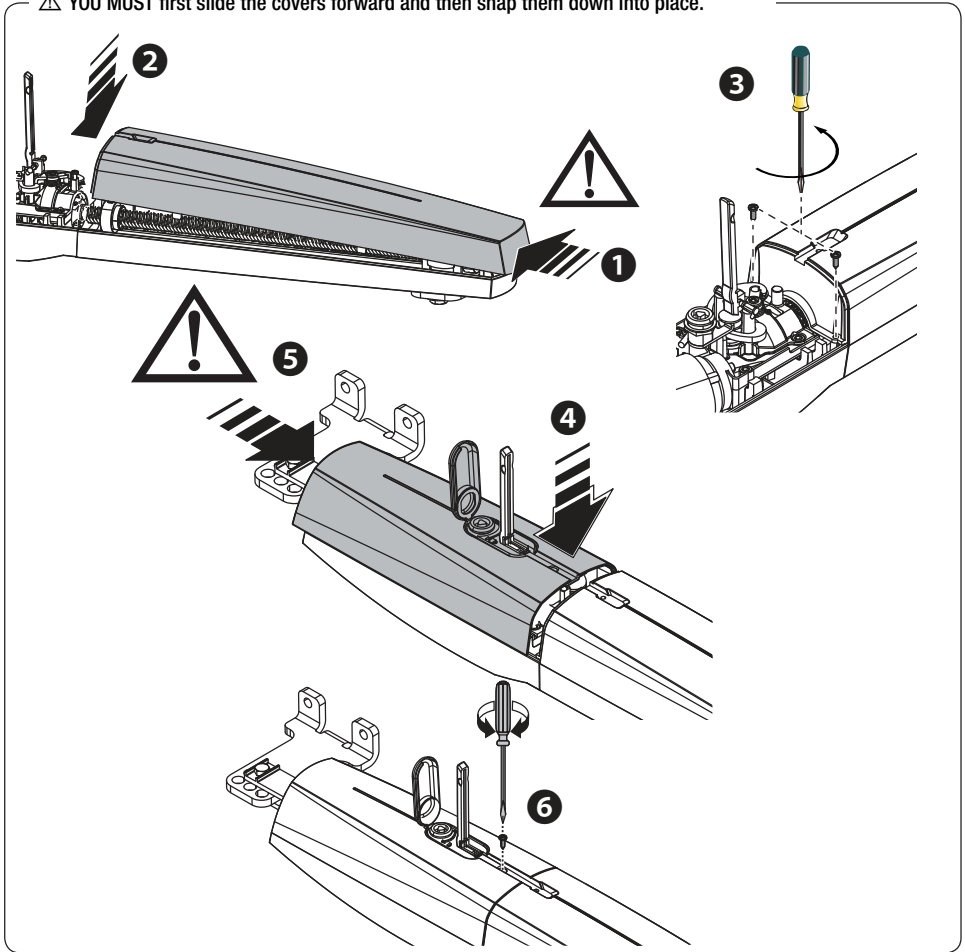

DISMANTLING AND DISPOSAL

☞ CAME CANCELLI AUTOMATICI S.p.A. applies a certified Environmental Management System at its premises, which is compliant with the UNI EN ISO 14001 standard to ensure the environment is safeguarded. Please continue safeguarding the environment. At CAME we consider it one of the fundamentals of our operating and market strategies. Simply follow these brief disposal guidelines:

DISPOSING OF THE PACKAGING

The packaging materials (cardboard, plastic, and so on) should be disposed of as solid household waste, and simply separated from other waste for recycling.

Always make sure you comply with local laws before dismantling and disposing of the product.

DISPOSE OF RESPONSIBLY!

DISMANTLING AND DISPOSAL

Our products are made of various materials. Most of these (aluminum, plastic, iron, electrical cables) are classified as solid household waste. They can be recycled by separating them before dumping at authorized city plants.

Whereas other components (control boards, batteries, transmitters, and so on) may contain hazardous pollutants.

These must therefore be disposed of by authorized, certified professional services.

Before disposing, it is always advisable to check with the specific laws that apply in your area.

DISPOSE OF RESPONSIBLY!

The contents of this manual may change, at any time, and without notice.



CAME.COM

CAME S.P.A.

Via Martiri Della Libertà, 15
31030 Dosson di Casier - Treviso - Italy
tel. (+39) 0422 4940 - fax. (+39) 0422 4941