

SLIDING DOOR OPERATOR

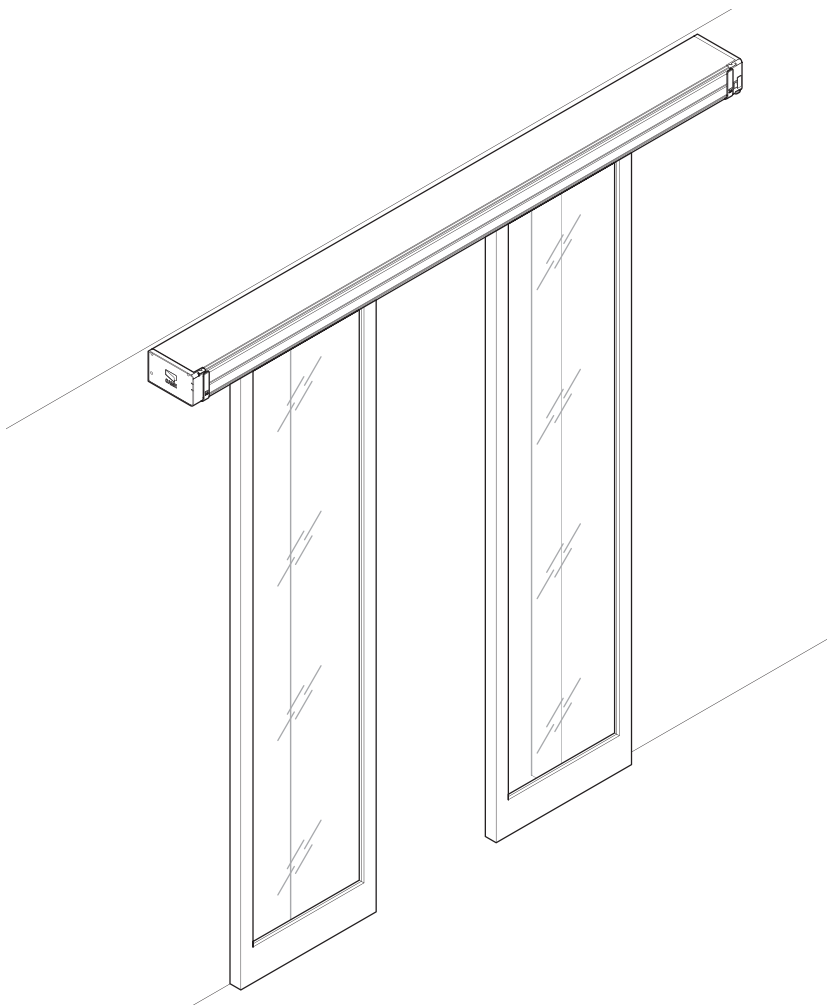

FA00323-EN



Official Partner



MILANO 2015

FEEDING THE PLANET
ENERGY FOR LIFE

ASSEMBLY AND INSTALLATION MANUAL

SIPARIO

EN English



WARNING!
important safety instructions for people:
READ CAREFULLY!



Premise

• Employ this product only for the use for which it was expressly made. Any other use is dangerous. CAME Cancelli Automatici S.p.A is not liable for any damage caused by improper, wrongful and unreasonable use • The safety of this product and its proper fitting depends, therefore, on respecting its technical characteristics and proper fitting, to be done in state-of-the-art fashion, and under safe conditions as expressly explained in the literature that comes with the product. • Keep these warnings together with the installation and operation manuals that come with the operator.

Before installing

(do not continue until you have complied with all safety provisions)

• Fitting and testing must be only performed by qualified technicians. Laying the cables, installation and testing must follow state-of-the-art procedures as dictated by regulations • Before beginning any operation it is mandatory to carefully read all instructions as improper installation may result in serious harm to people and things. • Make sure the door or leaf is in good mechanical state, balanced and aligned, and that it opens and closes properly. Also, install suitable protections, if needed, as well as additional safety sensors • If the operator is to be installed at a height of over 2.5 m from the ground or other access level, make sure you have any necessary protections and/or warnings in place • If any pedestrian openings are fitted into the operator, there must also be a system to block their opening while they are moving • Make sure that the opening automated door or gate cannot entrap people against the fixed parts of the operator • Do not install the operator upside down or onto elements that could yield and bend. If necessary, add suitable reinforcements to the anchoring points • Do not install door or gate leaves on tilted surfaces • Make sure any sprinkler systems cannot wet the operator from the ground up • Make sure the temperature range shown on the product literature is suitable to the climate where it will be installed as explained in the manual.

Installing

• Suitably section off and demarcate the entire installation site to prevent unauthorized persons from entering the area, especially minors and children. • Be careful when handling operators that weigh over 20 kg. If need be, use proper safety hoisting equipment • The CE-marked safety devices (photocells, stepping plates, sensitive safety-edges, emergency buttons, and so on), must be fitted in compliance with the regulations in effect and according to state-of-the-art criteria, taking into account the environment, the type of required service and of the working forces applied to moving leaves. Any shearing or conveying points must be sensor-protected • Any residual risks must be pointed out to endusers and highlighted with pictograms as provided by the law. • All opening commands (that is, buttons, key switches, magnetic readers, and so on) must be installed at least 1.85 m from the perimeter of the gate's working area, or where they cannot be reached from outside the gate. Also, any direct commands (buttons, touch panels, and so on) must be installed at least 1.5 m from the ground and must not be reachable by unauthorized persons • The automatic pedestrian closing must visibly show its identification data. • Before connecting the main power supply make sure that the identification data correspond to the those of the network • The automatic pedestrian closing must be connected to an effective regulation grounding system • The manufacturer declines any liability for using non-original products; which would result in warranty loss • All maintained action commands, must be fitted in places from which the moving gate leaves and transit and driving areas are visible • Apply, if missing, a permanent sign showing the position of the release device • Before delivering to the users, make sure the system is EN 12453 and EN 12445 standard compliant (regarding impact forces), and also make sure the system has been properly adjusted and that any safety, protection and manual release devices are working properly • Apply Warning Signs where necessary and in a visible place.

Special user-instructions and recommendations

• Keep gate operation areas clean and free of any obstructions. Make sure the photocell's operating field is clear of any obstructions • Do not allow children to play with fixed commands, or to loiter in the gate's maneuvering area. Keep any remote control transmitters or any other command device away from children, to prevent the operator from being accidentally activated. The apparatus may be used by children of eight years and above and by physically, mentally and sensorially challenged people, or even ones without any experience, provided this happens under close supervision or once they have been properly instructed to use the apparatus safely and about the potential hazards involved. Children must not play with the apparatus. Cleaning and maintenance must not be done by children, unless properly supervised •

Frequently check the system for any malfunctions or signs of wear and tear or damage to the moving structures, to the component parts, all anchoring points, including cables and any accessible connections. Keep any hinges, moving joints and slide rails properly lubricated • Perform functional checks on the photocells and sensitive safety edges, every six months. Constantly clean the photocells' glass covers using a slightly water-moistened cloth; do not use solvents or chemicals that could damage the devices • If repairs or modifications are required to the system, release the operator and do not use it until safety conditions have been restored • Cut off the power supply before releasing the operator for manual openings and before any other operation, to prevent potentially hazardous situations. Read the instructions • If the power supply cable is damaged, it must be replaced by the manufacturer or authorized technical assistance service, or in any case, by similarly qualified persons, to prevent any risk • It is FORBIDDEN for users to perform any OPERATIONS THAT ARE NOT EXPRESSLY REQUIRED OF THEM AND WHICH ARE NOT LISTED in the manuals. For any repairs, modifications and adjustments and for extra-ordinary maintenance, CALL TECHNICAL ASSISTANCE • Log the jobs and checks into the periodic maintenance log.

Additional special recommendations for everyone

• Keep away from hinges and mechanical moving parts • Do not enter the operator's area of operation when it is moving • Do not counter the operator's movement as this could result in dangerous situations • Always pay special attention to any dangerous points, which have to be labeled with specific pictograms and/or black and yellow stripes • When using a selector switch or a command in maintained actions, keep checking that there are no persons within the operating range of any moving parts, until the command is released • The gate may move at any time and without warning • Always cut off the power supply before performing any maintenance or cleaning.





Danger of hand crushing



Danger! High voltage.

LEGEND OF SYMBOLS AND GLOSSARY

-  This symbol shows which parts to read carefully.
 This symbol shows which parts describe safety issues
 This symbol shows which parts to tell users about.
 T = Overall operator length
 LT = Beam length
 A = Overall width of the leaves complete with gaskets
 Vp = Passage width
 LC = Profile cover length
 PA = Attaching-profile length
 LG = Gasket length
 LS = Dust brush length
 S = Overlap between leaf or moving leaf and fixed parts (masonry work)

REFERENCE REGULATIONS

Came Cancelli Automatici S.p.A. is certified for the: ISO 9001 quality and ISO 14001 environmental management systems. This product complies with the current regulations mentioned in the declaration of conformity.

DESCRIPTION

Sliding door operator for one or two leaves, with carriage system and leaf-diving belt.

 Any installation and/or use other than that specified in this manual is forbidden.

Limits to use

| Model | SIPARIO1 | SIPARIO2 |
|---|-------------|--------------------------------------|
| Leaf length (mm) | 660 ÷ 3350 | 920 (460 + 460) ÷ 3350 (1675 + 1675) |
| Beam length (mm) | 1346 ÷ 6726 | 1866 ÷ 6726 |
| Maximum gate-leaf weight (kg) | 100 | 200 (100 + 100) |
| Minimum overlapping of gate-leaves (mm) | 20 | 20 |

Dimensions (mm)

| Model | SIPARIO1 | SIPARIO2 |
|-------|----------|----------|
| T min | 1346 | 1866 |
| T max | 6726 | 6726 |
| H | 100 | 100 |
| P | 170 | 170 |

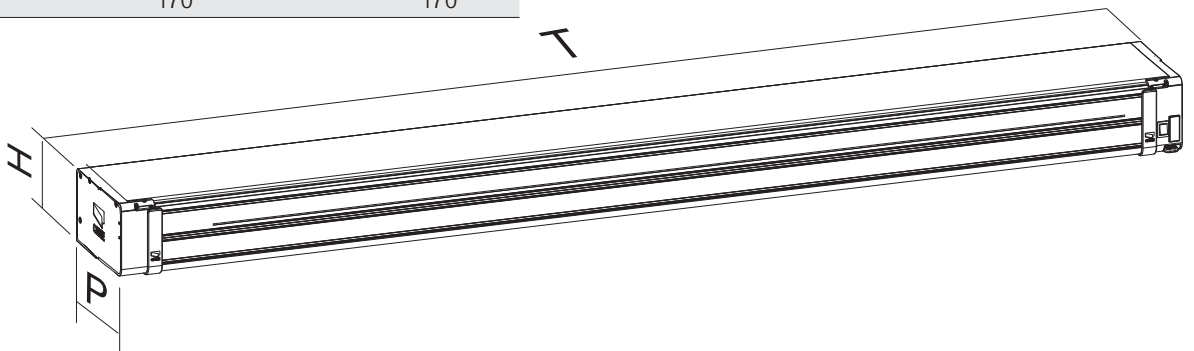

Technical data

| Type | SIPARIO1 - SIPARIO2 |
|---|---------------------|
| Protection rating (IP) | 40 |
| Power supply (V - 50/60 Hz) | 120 - 230 AC |
| Power supply motor (V) | 24 DC |
| Draw (A) | 5.3 |
| Motor power(W) | 220 |
| Electroblock power (W) | 15 |
| Control panel and accessories consumption (W) | 18 |
| Maximum maneuvering speed (m/s) | 0.8 |
| Duty cycle | INTENSIVE USE |
| Operating temperature (°C) | -20 ÷ +55 |
| Thrust (kg) | 5 |
| Weight (kg) | - |

Description of parts

- | | | |
|-----------------------------|-------------------------------|---------------------------------|
| 1. End cap (left) | 8. Brush | 15. Transformer |
| 2. Anti-release screw | 9. Carriage | 16. Profile cover support lever |
| 3. Profile cover spring-pin | 10. Belt attachment | 17. Switch |
| 4. Closing stop | 11. Auxiliary battery housing | 18. Release lever |
| 5. Mechanical leaf stop | 12. Profile cover | 19. Fuse housing |
| 6. Belt winder | 13. Control board | 20. End cap (right) |
| 7. Belt | 14. Gearmotor | |

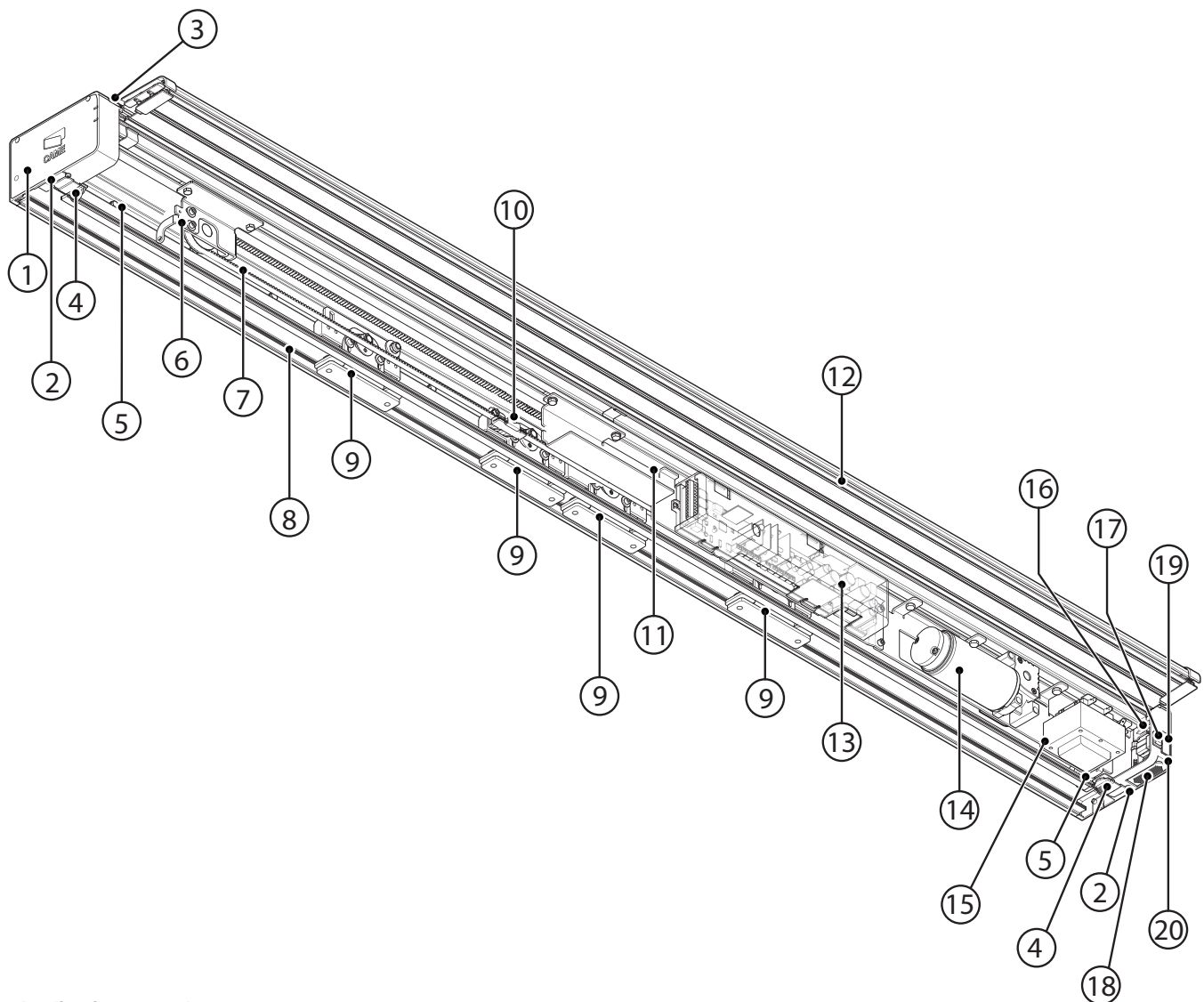

Applicative examples

OPERATOR FOR TWO-LEAVED SLIDING DOOR

| | |
|----|------------------------------|
| A | $V_p + (2 \times S)$ |
| T | $A \times 2 + 26 \text{ mm}$ |
| LT | $LT = T - 26 \text{ mm}$ |

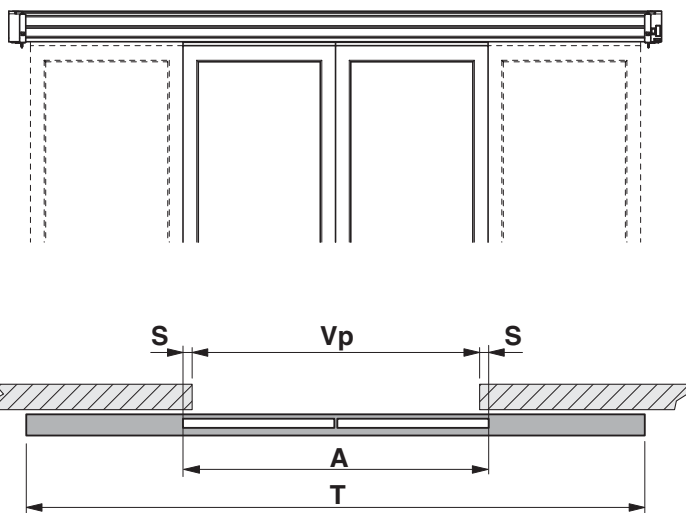

OPERATOR FOR ONE-LEAVED SLIDING DOOR

| | |
|----|------------------------------|
| As | $V_p + (2 \times S)$ |
| T | $A \times 2 + 26 \text{ mm}$ |
| LT | $LT = T - 26 \text{ mm}$ |

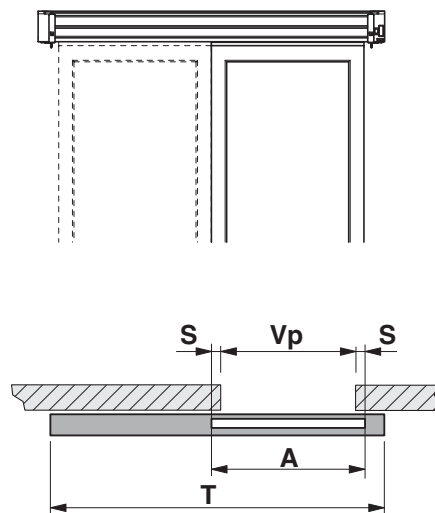

SIPARIO kit components list

001MSIPARIO

Complete system with **reversible gear-motor** for door with one or two sliding leaves up to 100 kg per leaf

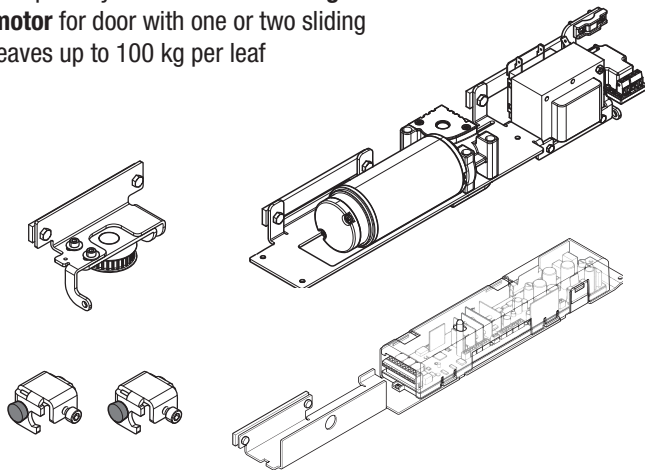

001SIPA16

Package of guide carriages and belt attachment for one-leaved sliding door

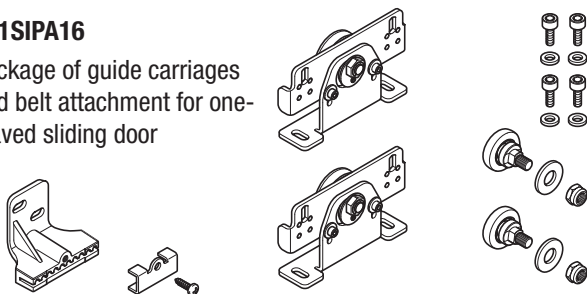

001SIPA02 (optional)

Complete electro-block

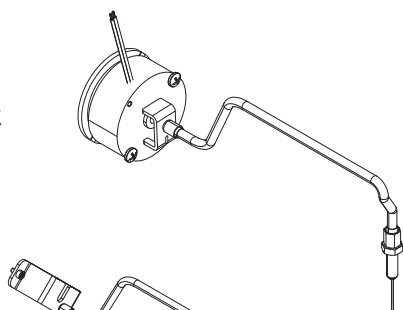

001SIPA07 (optional)

Supplementary cord release

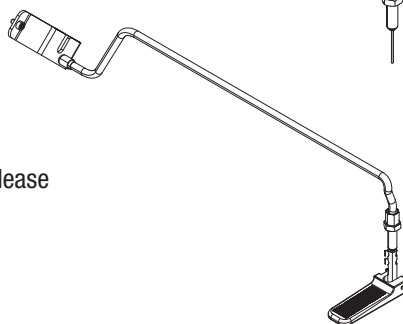

001SIPA03 (optional)

Features selector

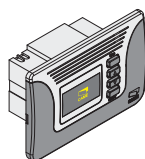

001SIPA04 (optional)

Transceiver selector



001SIPC68SET / 001SIPC68GSET

Profile cover

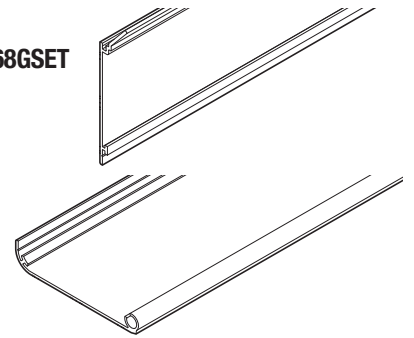

001SIPT68SET

Beam profile L = 6850 mm

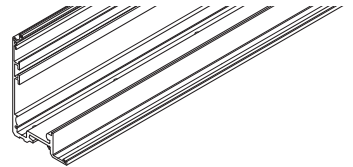

001SIPT67SET

Perforated beam-profile L = 6700 mm

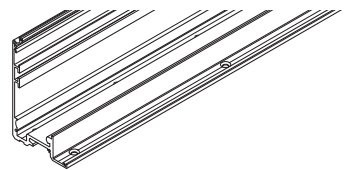

001SIPP68SET (optional)

Wall-hooking profile L = 6850 mm

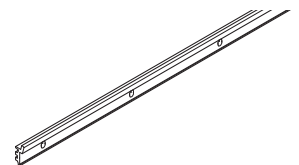

001SIPA17

Package of 30 meters of belt

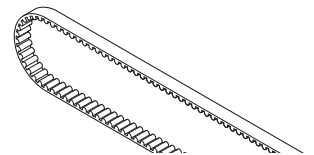

001SIPA18

Dustcover package 30 meters

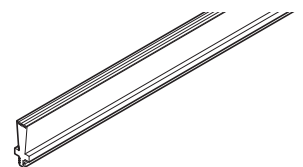

001SIPA19

Gasket package 30 meters

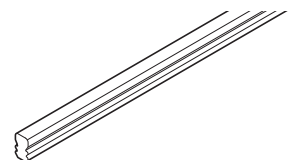

001SIPTL

Package of end caps

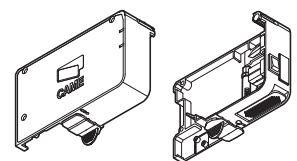

001SIPA10

Package of 10 hinges

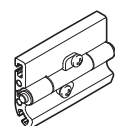

List of Sipario components

001SIPARIO1

Operator for one sliding leaf weighing up to 100 kg.

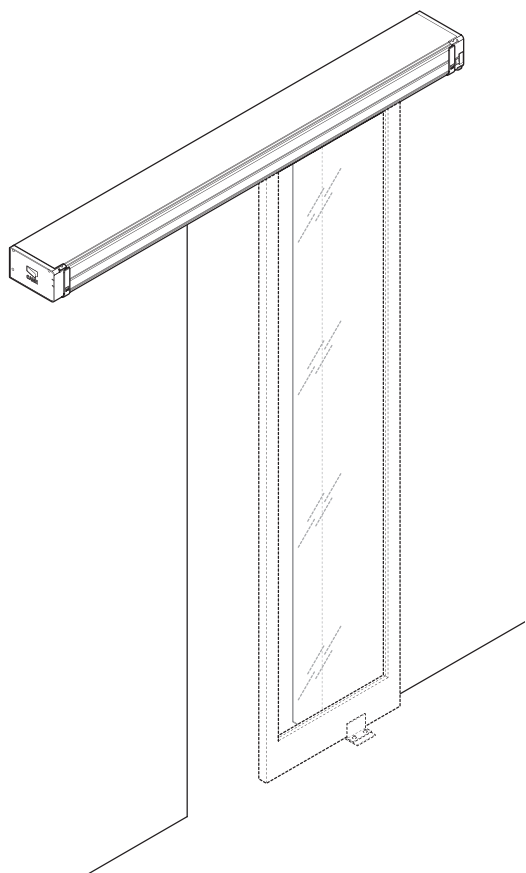

001SIPARIO2

Operator for two sliding leaves weighing up to 100 kg per leaf.

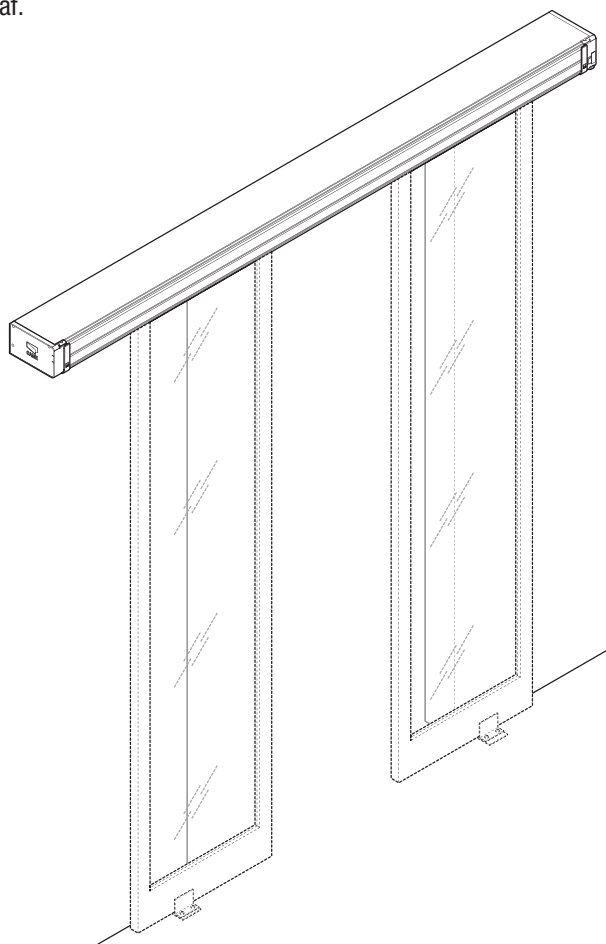

001SIPC

Anodized aluminum profile cover complete with dust-cover and hinges

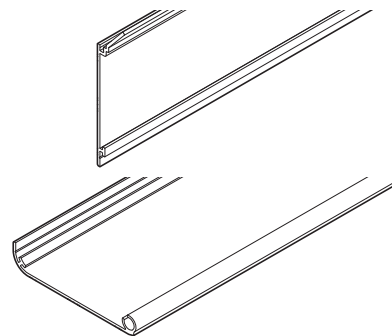

001SIPCG

Rough aluminum profile cover complete with dust guard and hinges

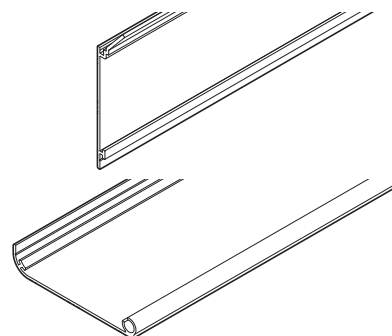

001SIPTR

Anodized aluminum perforated profile cover

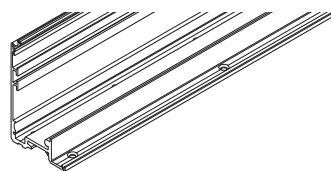

001SIPP (optional)

Wall attaching profile

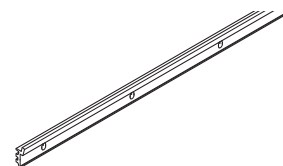

Standard installation

1. Operator
2. Adjustable-range
3. Keypad selector
4. Volumetric touch sensor
5. Features selector
6. Transceiver features selector
7. Microphotocells
8. Sensitive floor-plate
9. Release lever
10. Safety box with release handle
11. Release device

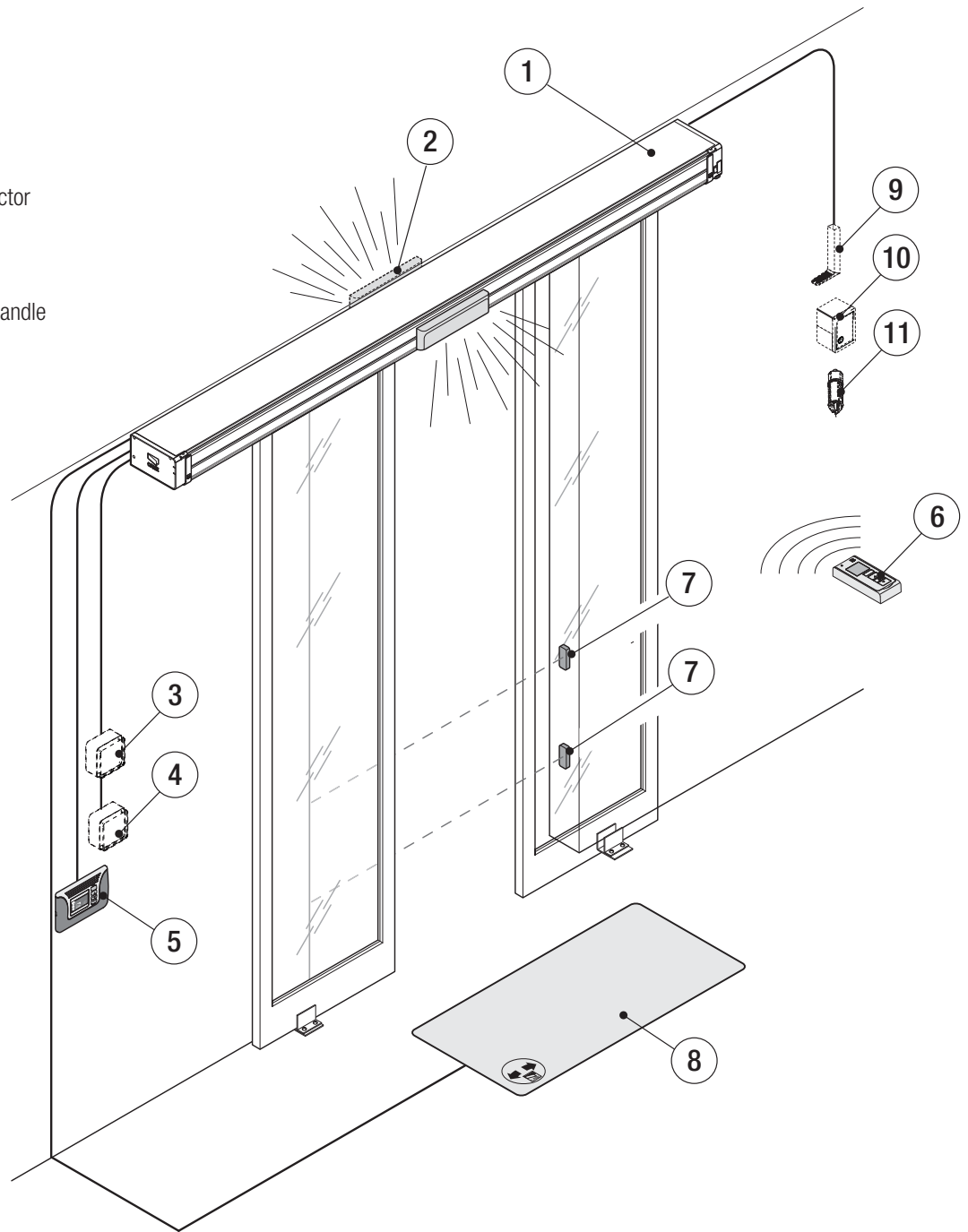

GENERAL INSTRUCTIONS FOR INSTALLING

△ Only skilled, qualified staff must install this product.

Preliminary checks

△ Before beginning the installation, do the following:

- Set up a dual pole cut off switch with minimum contact openings of 3 mm, and section-off the power supply;
- Set up suitable tubes and conduits for the electric cables to pass through, making sure they are protected from any mechanical damage;
- ⚡ Make sure that any connections inside the container (ones that ensure continuity to the protection circuit) are fitted with additional insulation with respect to those of other electrical parts inside;

Tools and materials

Make sure you have all the tools and materials you will need for installing in total safety and in compliance with applicable regulations. The figure shows some of the equipment installers will need.

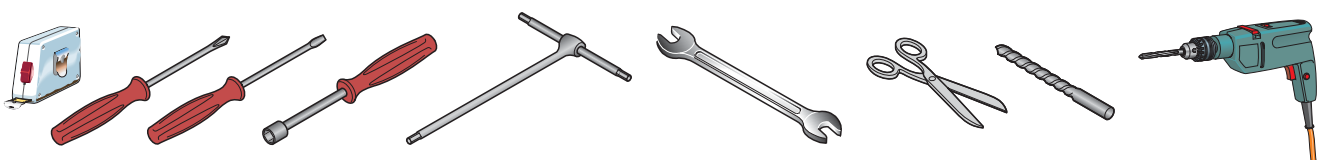

Cable types and minimum thicknesses

| Connection | Cable type | Cable length 1 < 10 m | Cable length 10 < 20 m | Cable length 20 < 30 m |
|---|---------------------------------------|--------------------------|---------------------------|---------------------------|
| Control panel power supply 230 V AC | FROR CEI 20-22 CEI EN 50267-2-1 | 3G x 1.5 mm ² | 3G x 2.5 mm ² | 3G x 4 mm ² |
| Command and safety device | | 2 x 0.5 mm ² | | |
| Photocell receivers (DIR, DELTA) | | 4 x 0.5 mm ² | | |
| Photocell transmitters (DIR, DELTA) | | 2 x 0.5 mm ² | | |
| Photocell transmitters and receivers (SIPA 08-09) | SHIELDED (supplied) | max 6 m | | |
| Antenna | RG58 | max 10 m | | |
| Paired or | CAT 5 - U/UTP - AWG 24 | max 100 m | | |
| Connection to the CRP (Came Remote Protocol) | CAT 5 - U/UTP - AWG 24 | max 1000 m | | |
| Metal mass detector | (see product literature) | | | |

ⓘ If cable lengths differ from those specified in the table, establish the cable sections depending on the actual power draw of the connected devices and according to the provisions of regulation CEI EN 60204-1.

For multiple, sequential loads along the same line, the dimensions on the table need to be recalculated according to the actual power draw and distances. If connecting products that are not contemplated in this manual, see the literature accompanying said products.

INSTALLATION

⚠ The following illustrations are just examples, in that the space available for fastening the operator and accessories varies depending on the overall dimensions. It is up to the installer/fitter, therefore, to choose the most suitable solution.

⚠ The operator must be mounted by at least two people. Use proper hoisting gear to transport and position the operator.

Check before fastening the beam

⚠ Depending on the distance between ceiling and passage width, the operator may be fastened in two ways:

- if the distance between ceiling and passage width is less than 110 mm, fasten the beam to the wall.

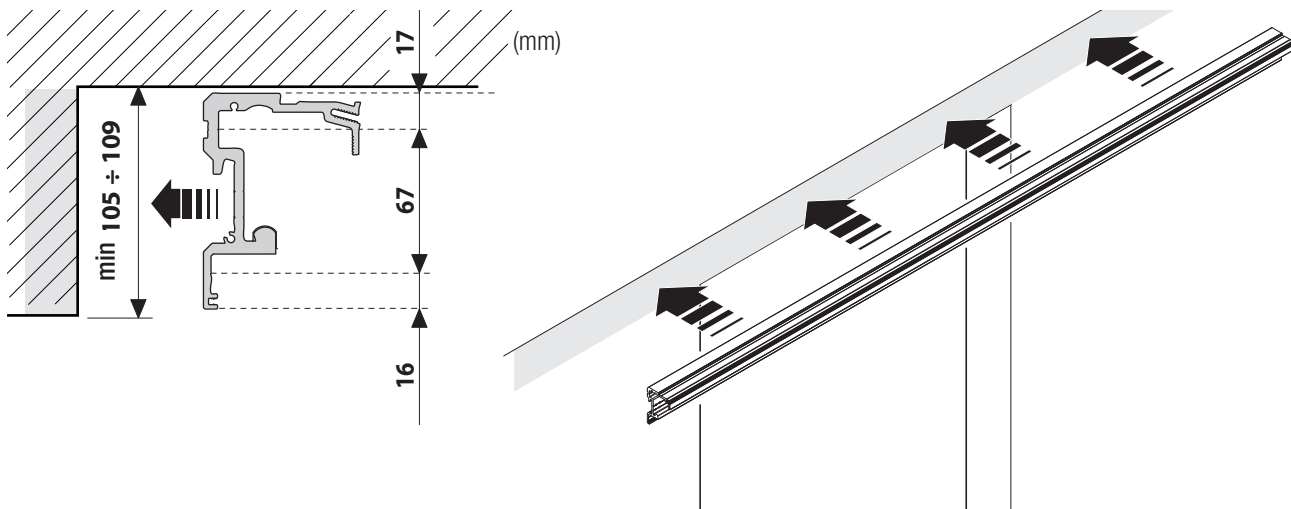

- if the distance between ceiling and passage width is more than 110 mm, fasten the beam to the wall or use the attaching profile. In the latter case, fastening the beam is simplified.

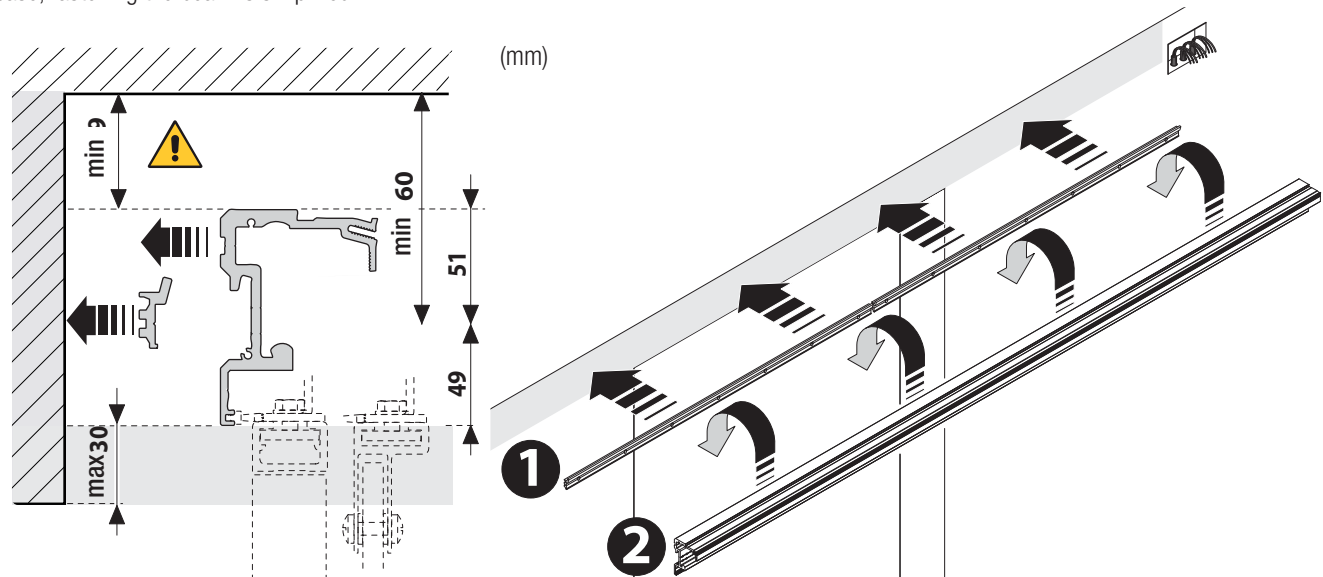

Measuring and cutting the beam and profile cover to measure

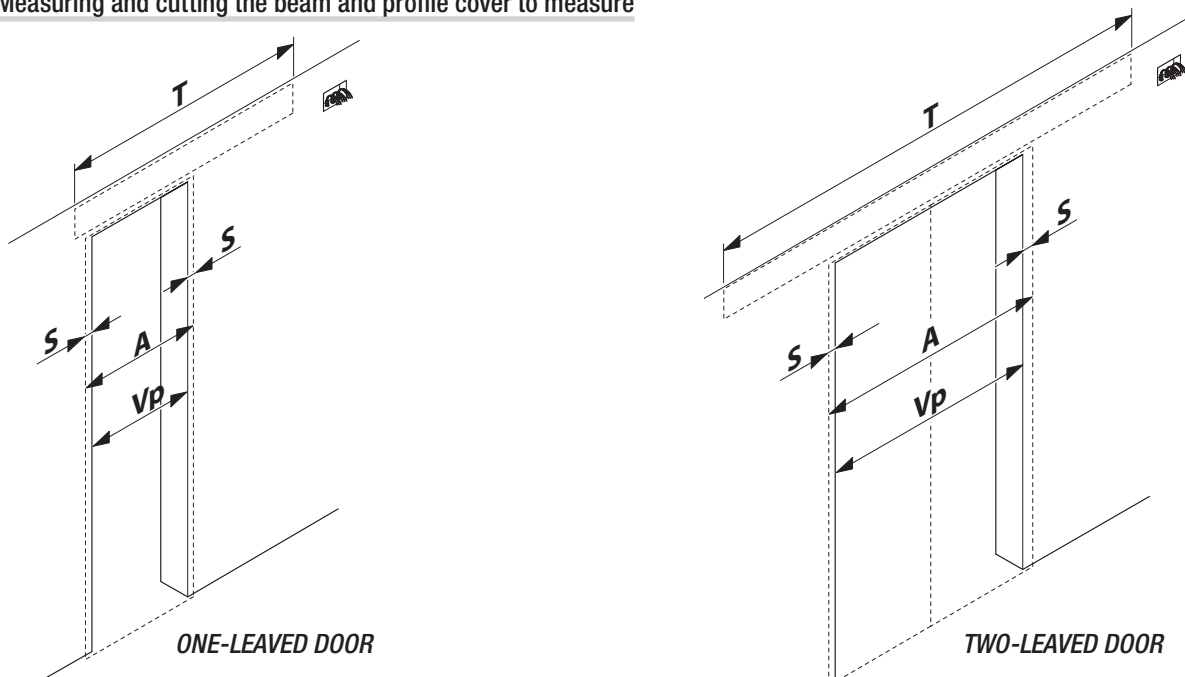

△ The two types of beam are supplied in standard measurements (001SIPT67SET L= 6700 mm and 001SIPT68SET L = 6850 mm).
 The beams should be cut based on the onsite needs.
 To cut the beam, measure starting from the end as shown in the figure.

$$T = A \times 2 + 26 \text{ mm}$$

$$LT = T - 26 \text{ mm}$$

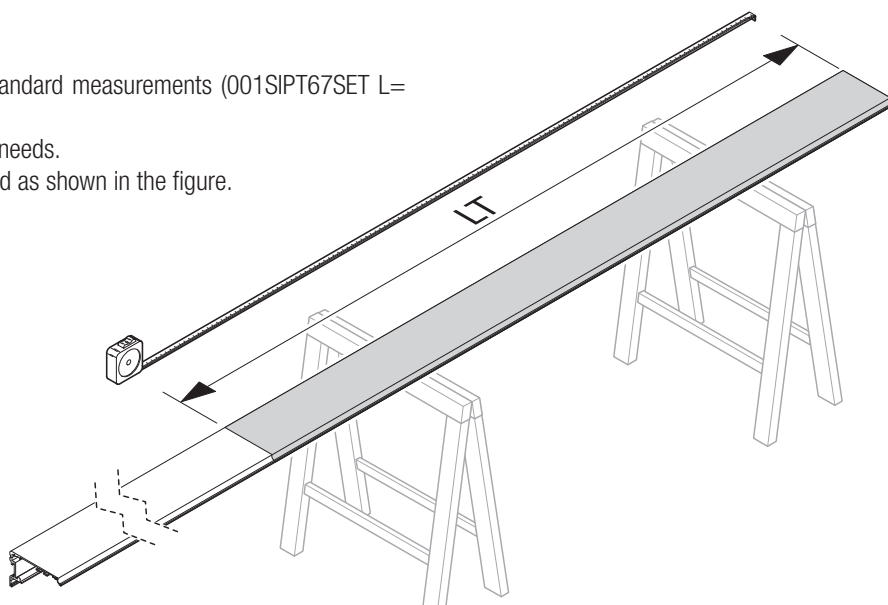

△ Profile covers (001SIPC68SET or 001SIPC68GSET) are supplied in the standard size (L = 6850 mm). They must be cut depending on your onsite needs.

$$LC = T - 94 \text{ mm}$$

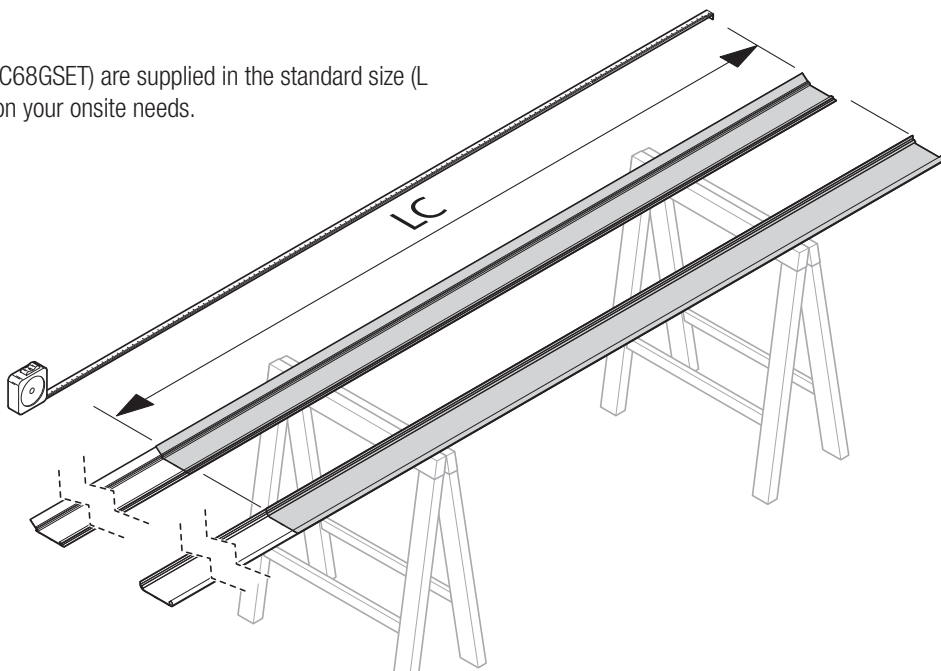

△ The (001SIPP68SET) attaching profile is supplied in standard size (L = 6850 mm). It needs to be cut depending on your onsite needs.

To cut the attaching profile, measure starting from the end as shown in the figure.

$$PA = T - 100 \text{ mm}$$

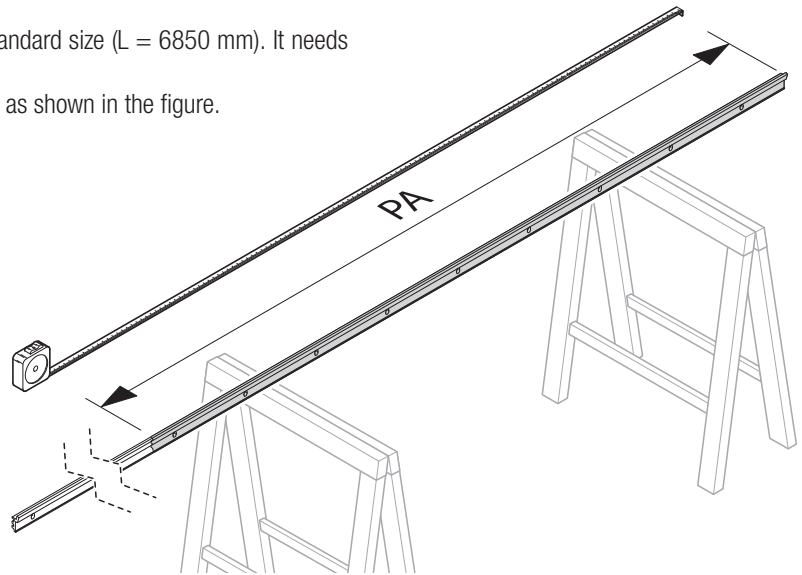

Drilling the beam

001SIPT68SET - After cutting the beam to the required size, drill two holes 40 mm apart from the right edge and two holes 40 mm apart from the left edge. Starting from the right, continue drilling at 250 mm intervals, as shown in the figure. **A.**

📖 Set up a Ø 25 mm hole to thread the electric cables in the most suitable place according to how the cables are, see figure **B.** It is up to the fitter to choose the most suitable solution.

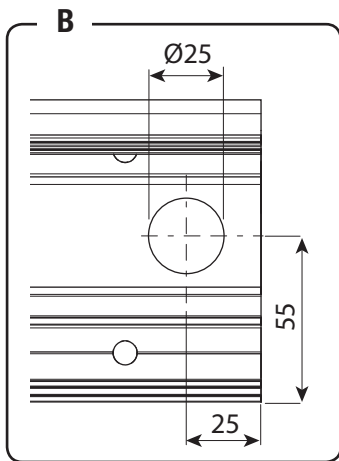
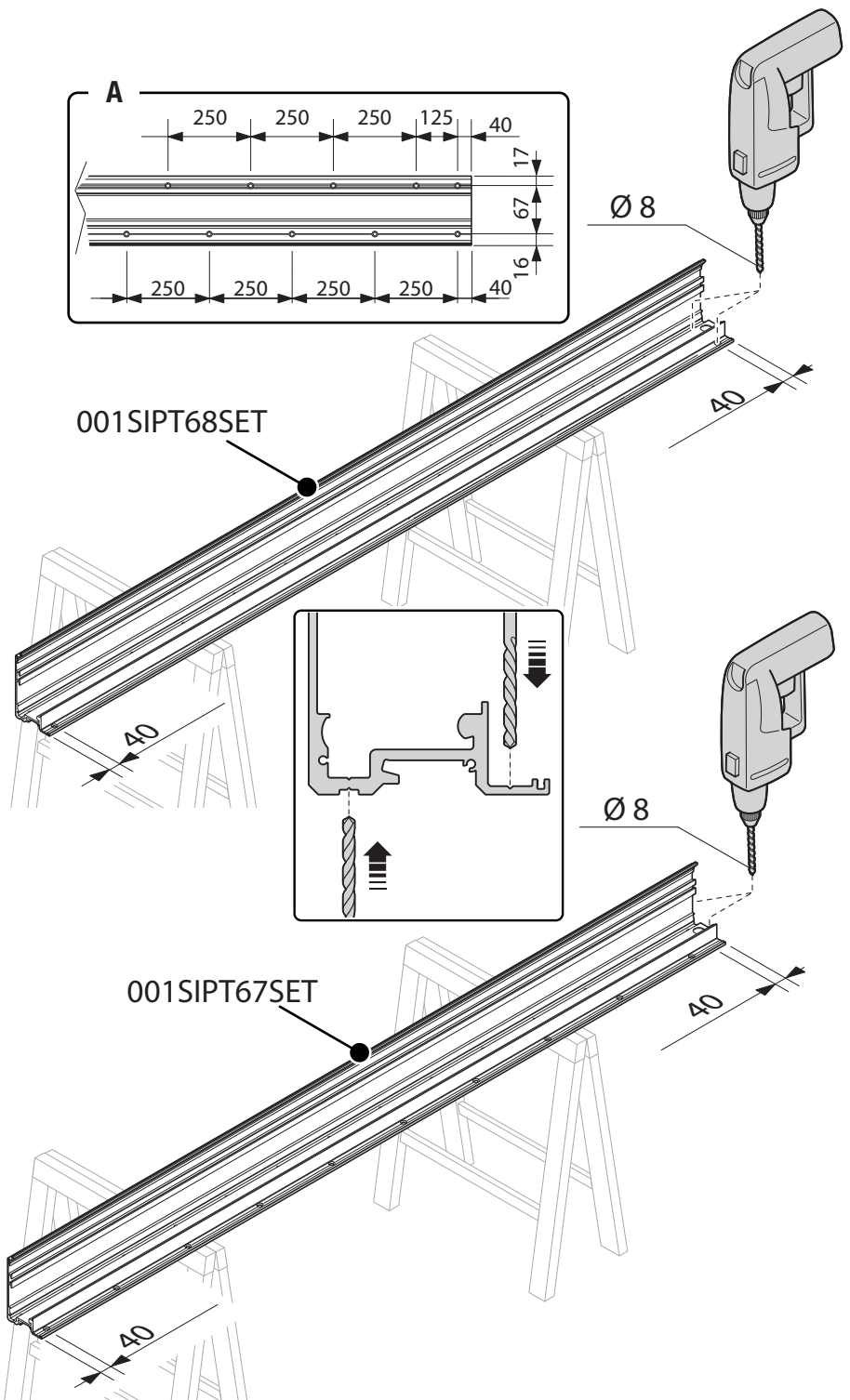
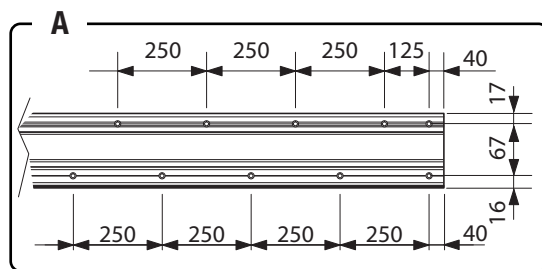

001SIPT67SET - After cutting the beam to the required size, drill two holes 40 mm apart from the right edge and two holes 40 mm apart from the left edge for the next wall fastening.

Tracing the holes

Without attaching profile - Level the beam **1** and mark the drilling points on the wall **2**.
Drill the marked points, fit the anchors **3**.

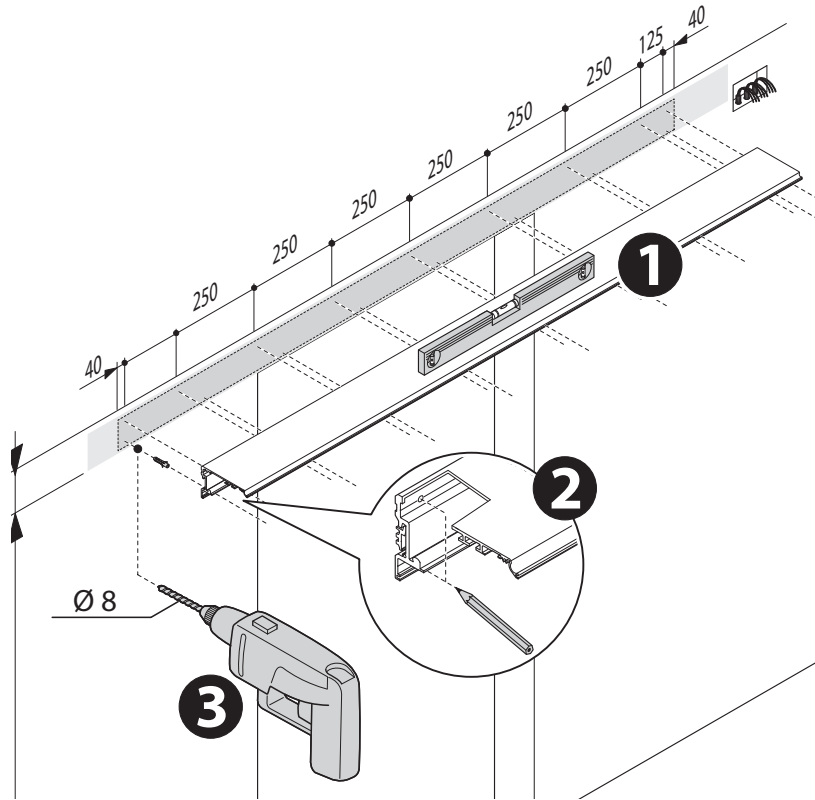

With attaching profile - Level the attaching profile **1** and mark the drilling holes on the wall; the attaching profile is preperforated.
Drill the marked holes **2**, fit the anchors and fasten the profile using bolts and washers **3**.
Hook the beam to the profile and mark a drilling point on the wall **4**, remove the beam **5**, drill **6** and fit the anchors **7**.

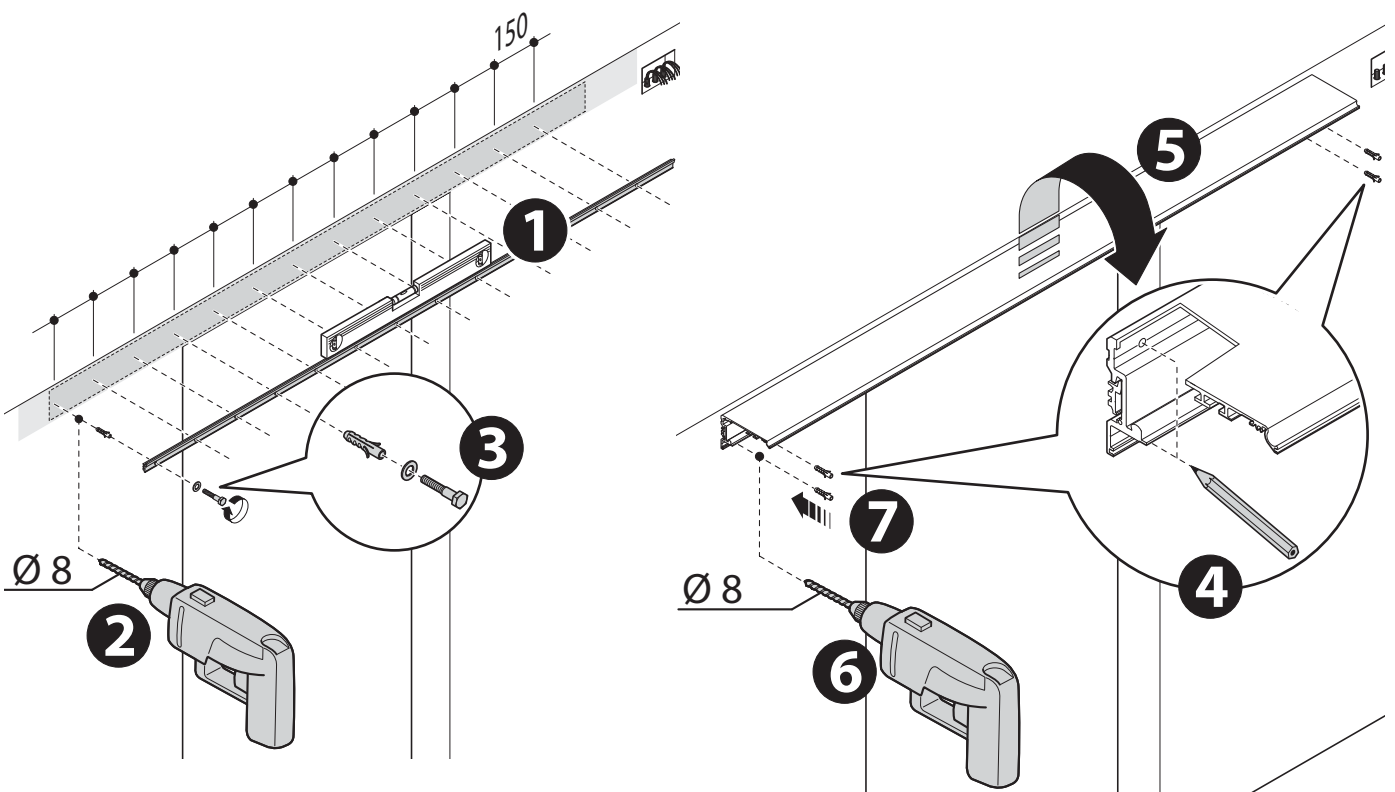

Gaskets and dust brush

Cut the gasket and dust brush to measure. The gasket should be fitted into the top of the beam **1** and the dust brush into the bottom **2**.

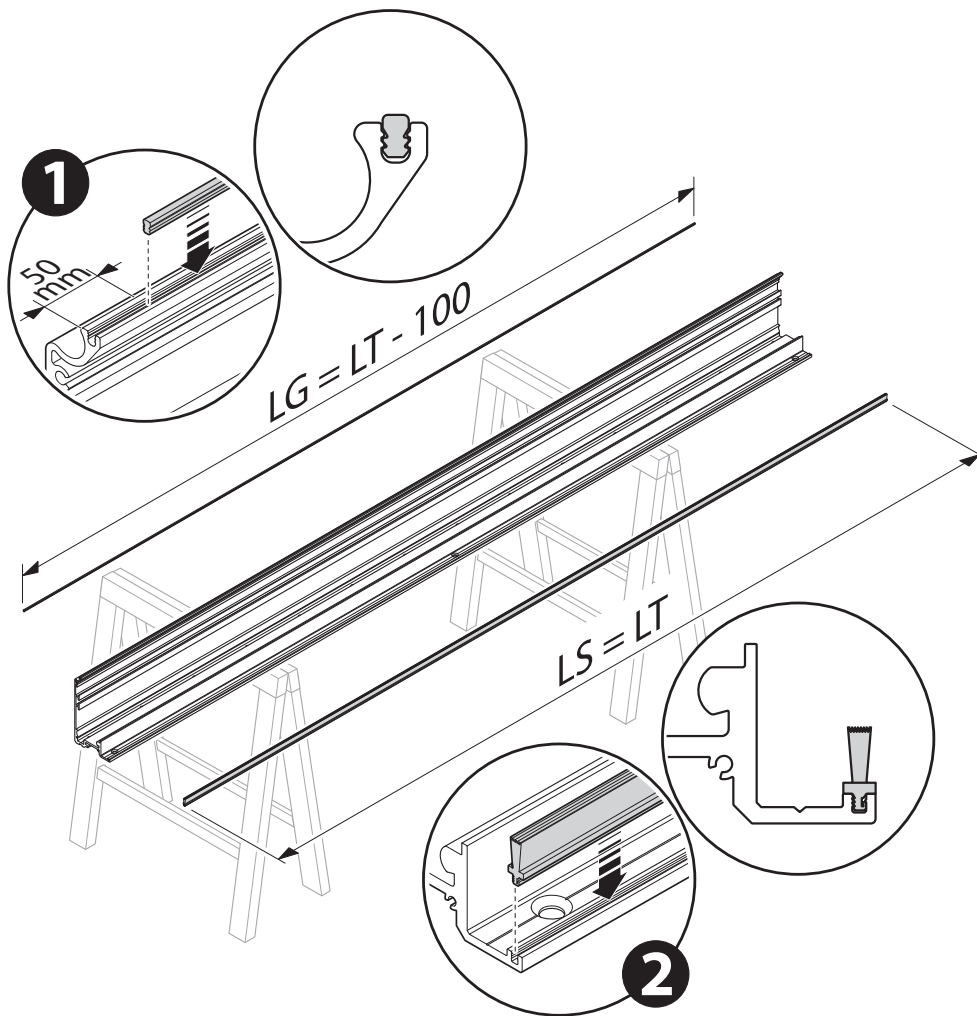

Fitting the fastening bracket for supporting the control board and the belt winder

To make gearmotor and control board installation easier, we suggest fitting a board support bracket as shown in the figure **1**. Fit the belt winder 25 mm from the edge **2** and fasten it using the hexagonal screw **3**.

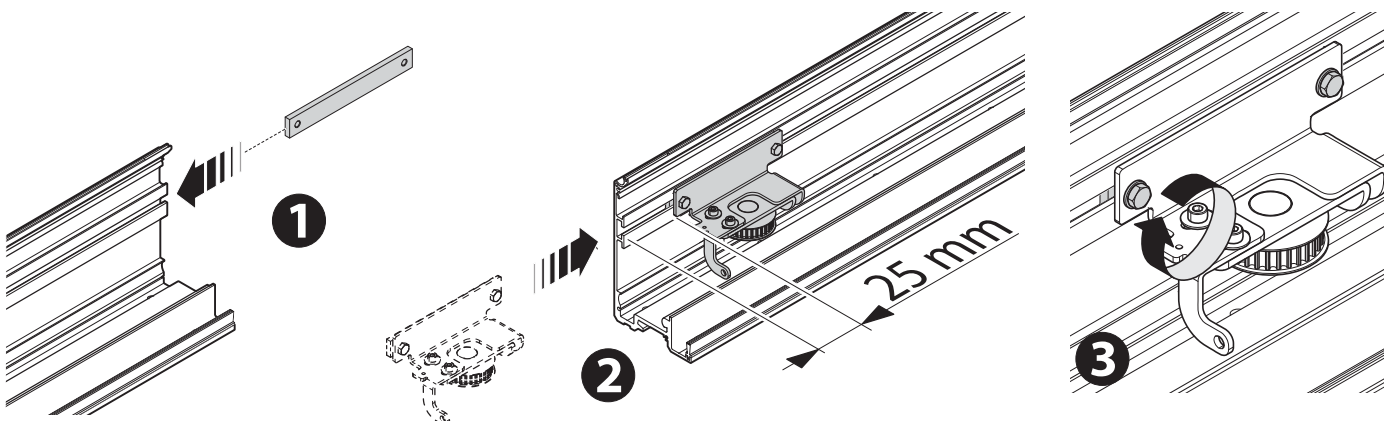

Fastening the gearmotor

Fit the gearmotor 65 mm from the edge and fasten it using the hexagonal screw.

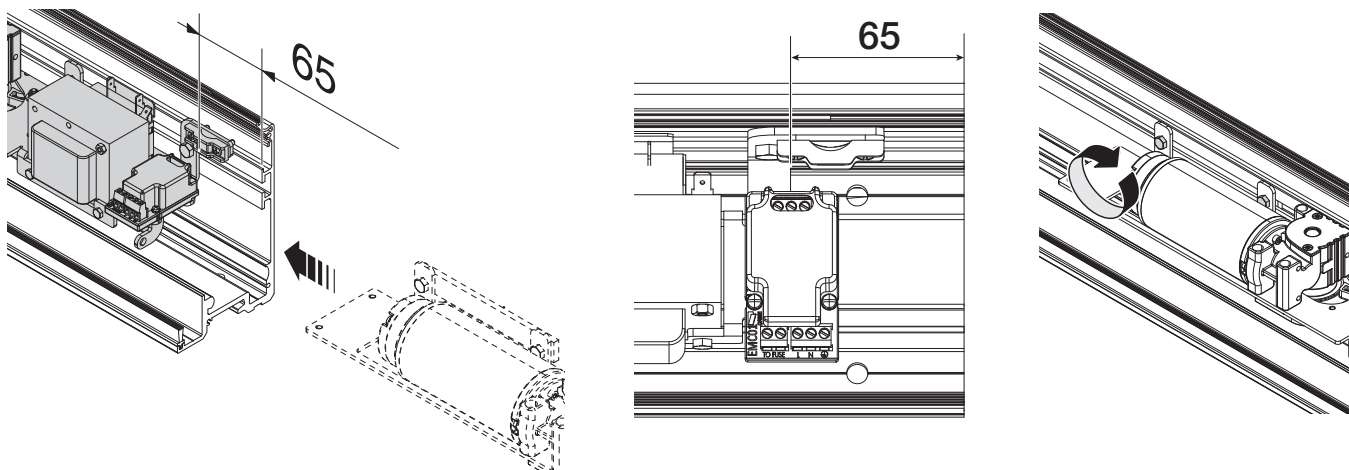

Fastening the mechanical stop and end caps

Fit the mechanical stops without tightening them (leave them loose).

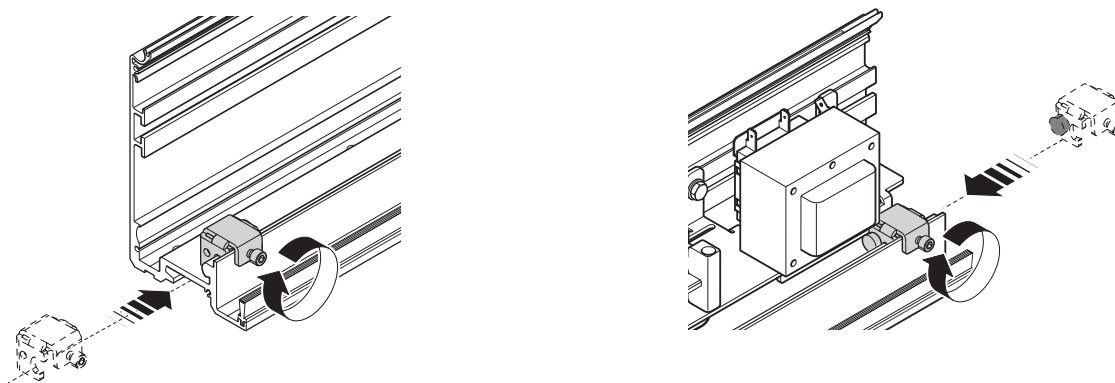

Fit both caps and fasten them using the supplied screws.

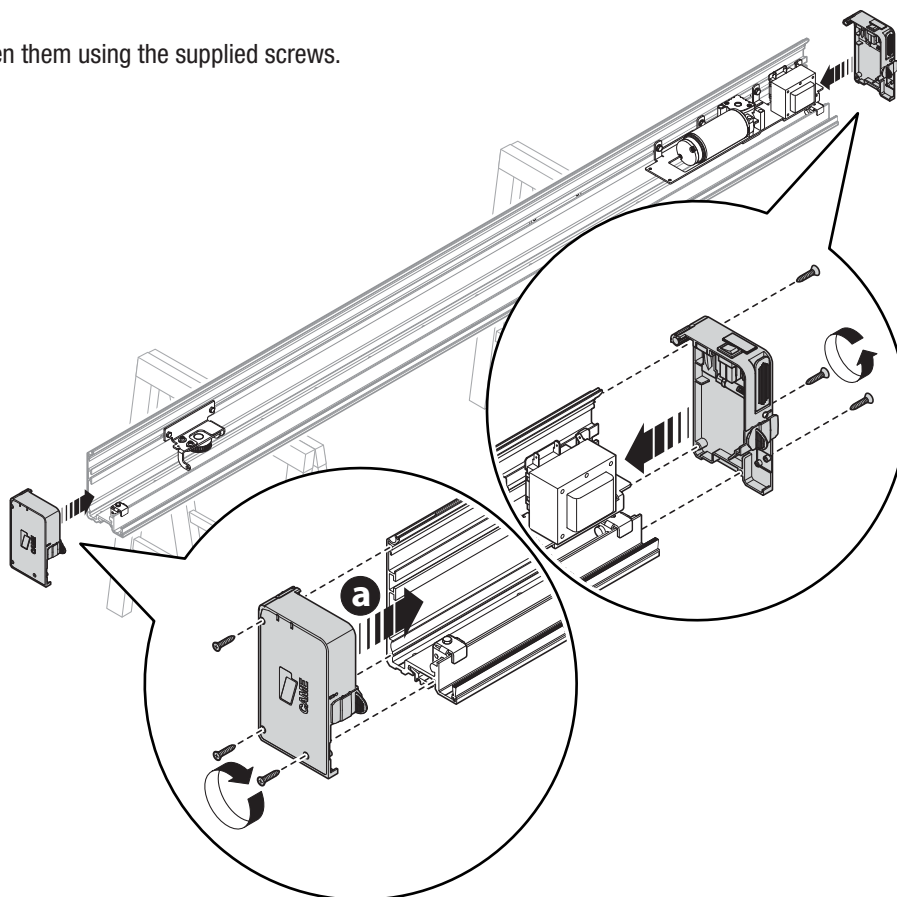

Fastening the beam

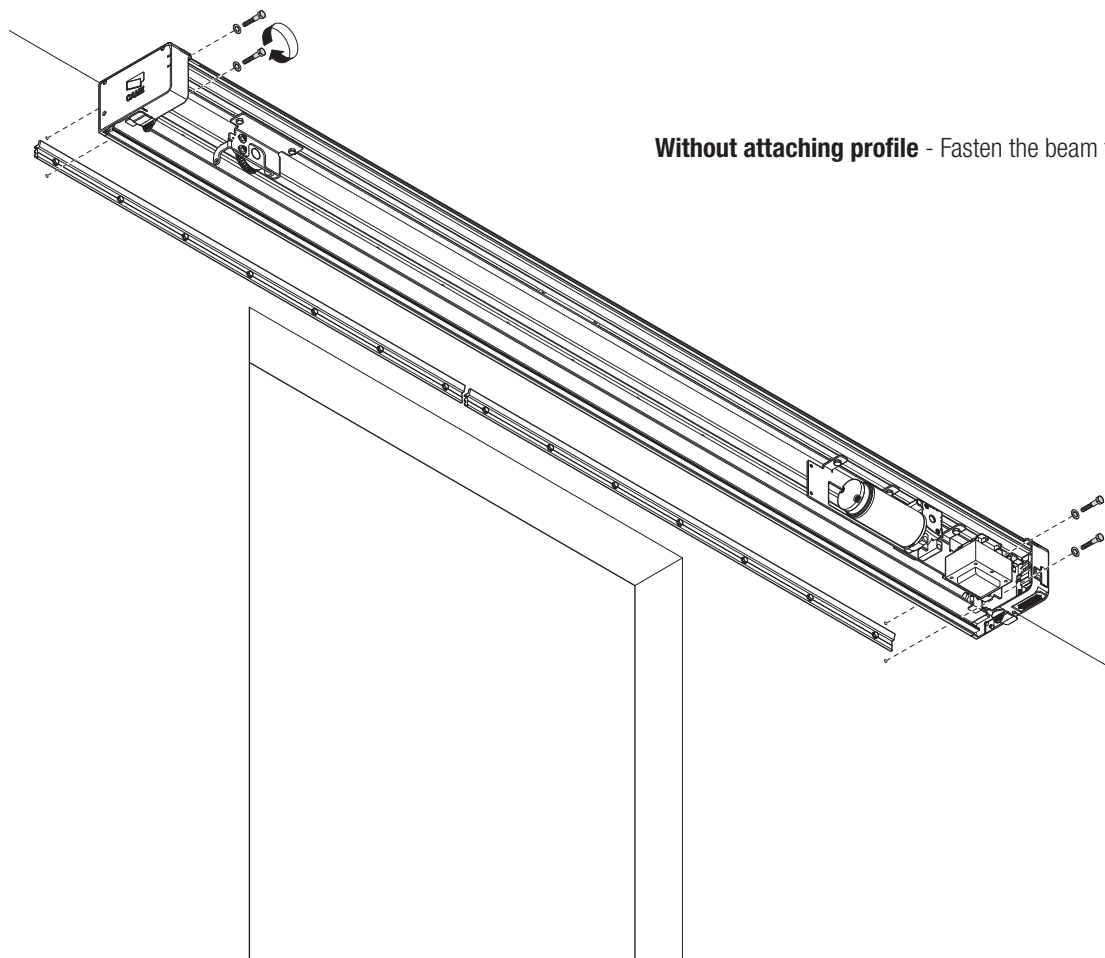

Without attaching profile - Fasten the beam to the wall.

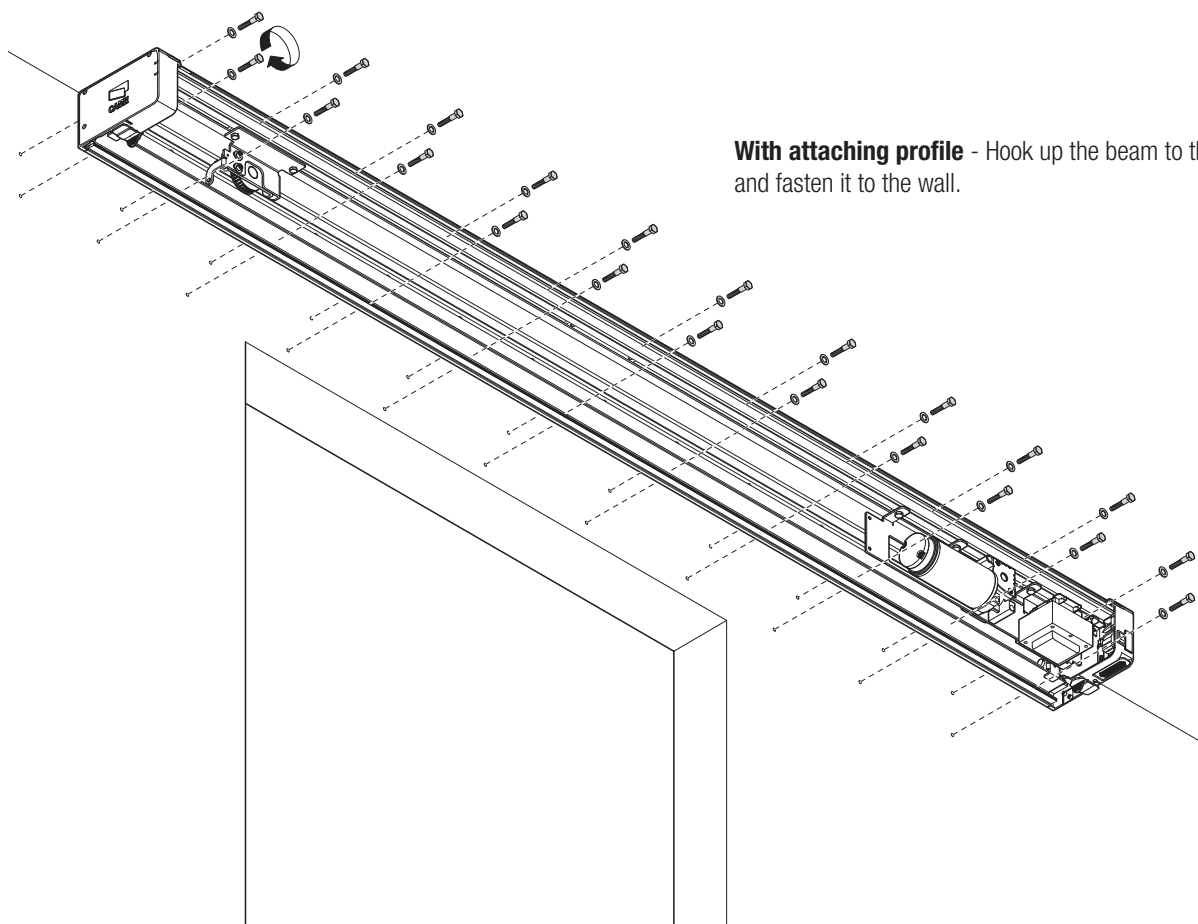

With attaching profile - Hook up the beam to the profile and fasten it to the wall.

Glass door-leaves

(mm)

| | |
|---|---|
| Y | Height from the ground for fastening the beam |
| H | Passage-width height |
| V | Height of glass |

$Y = H + (0 \div 30 \text{ mm})$
 $V = Y - 82 \text{ mm}$

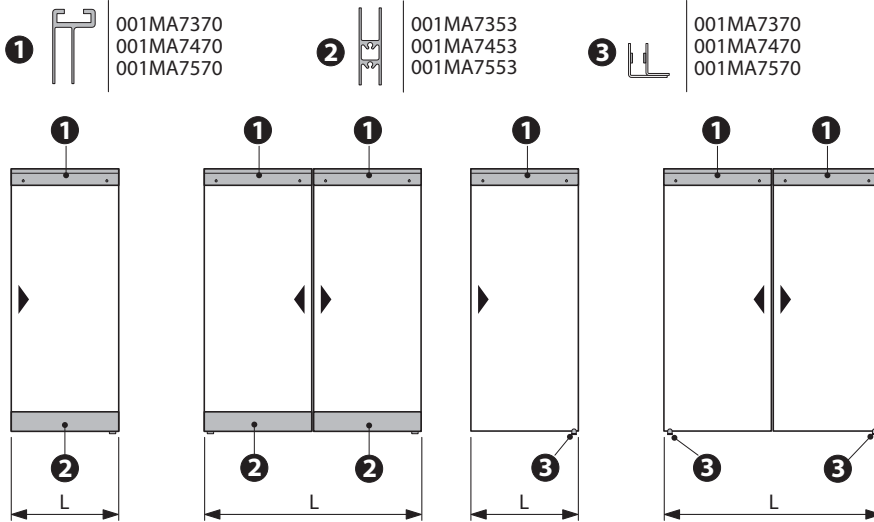
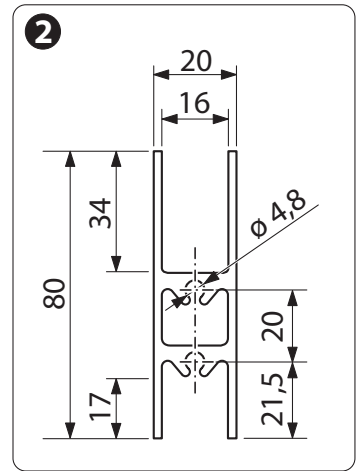
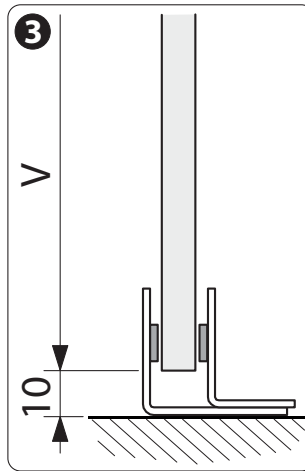
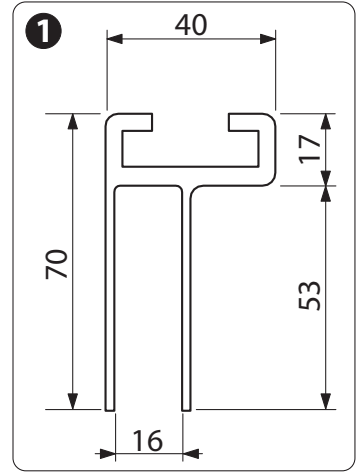
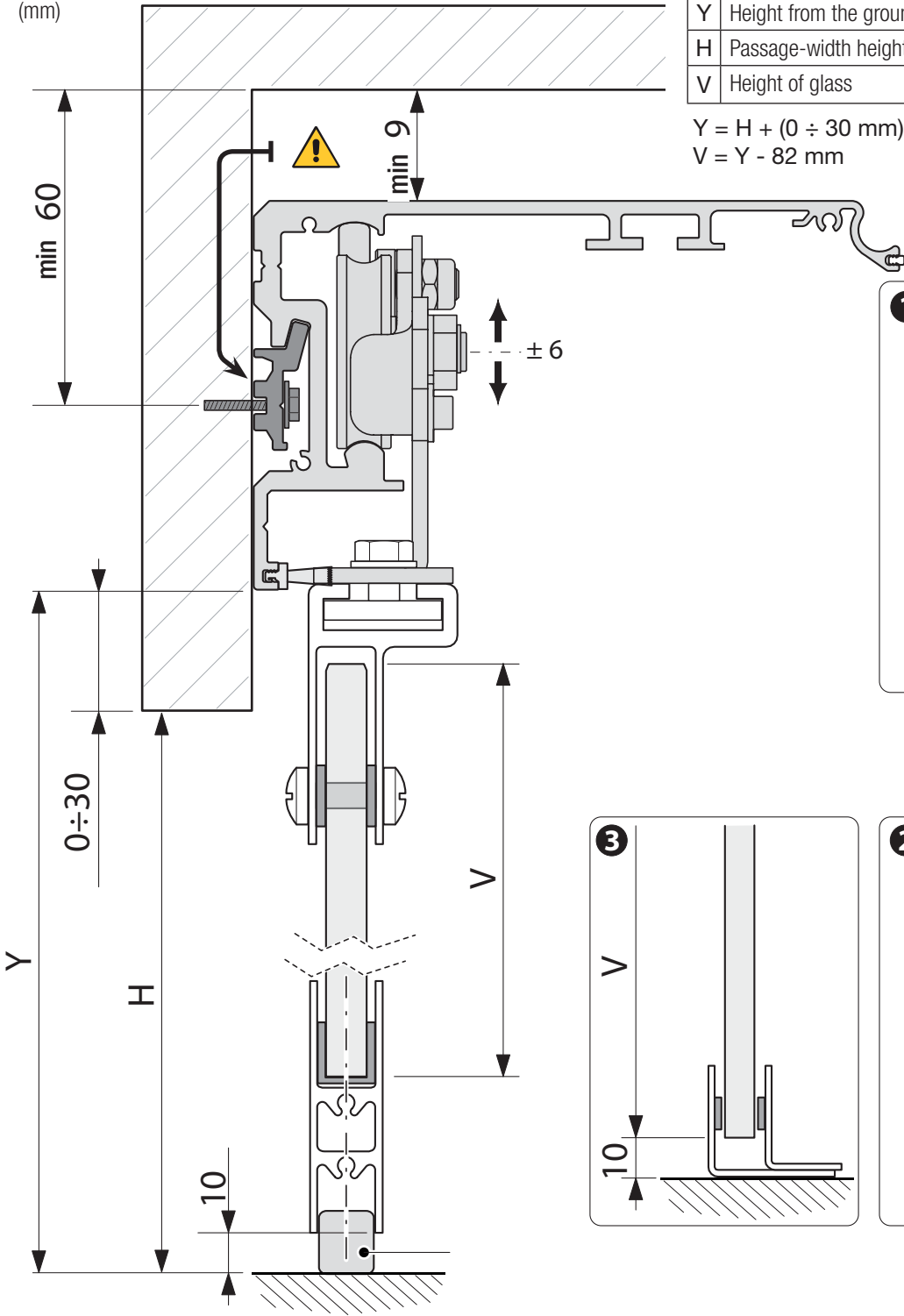

Drilling hole distances for glass and upper profile

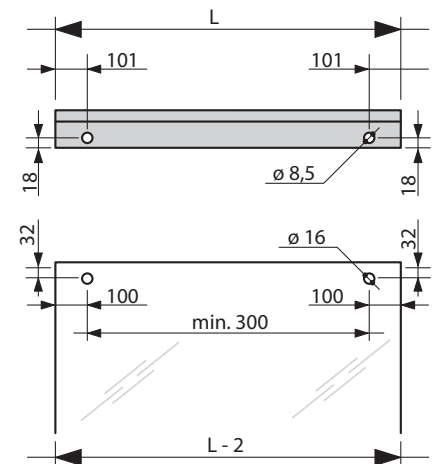

Framed door-leaves

(mm)

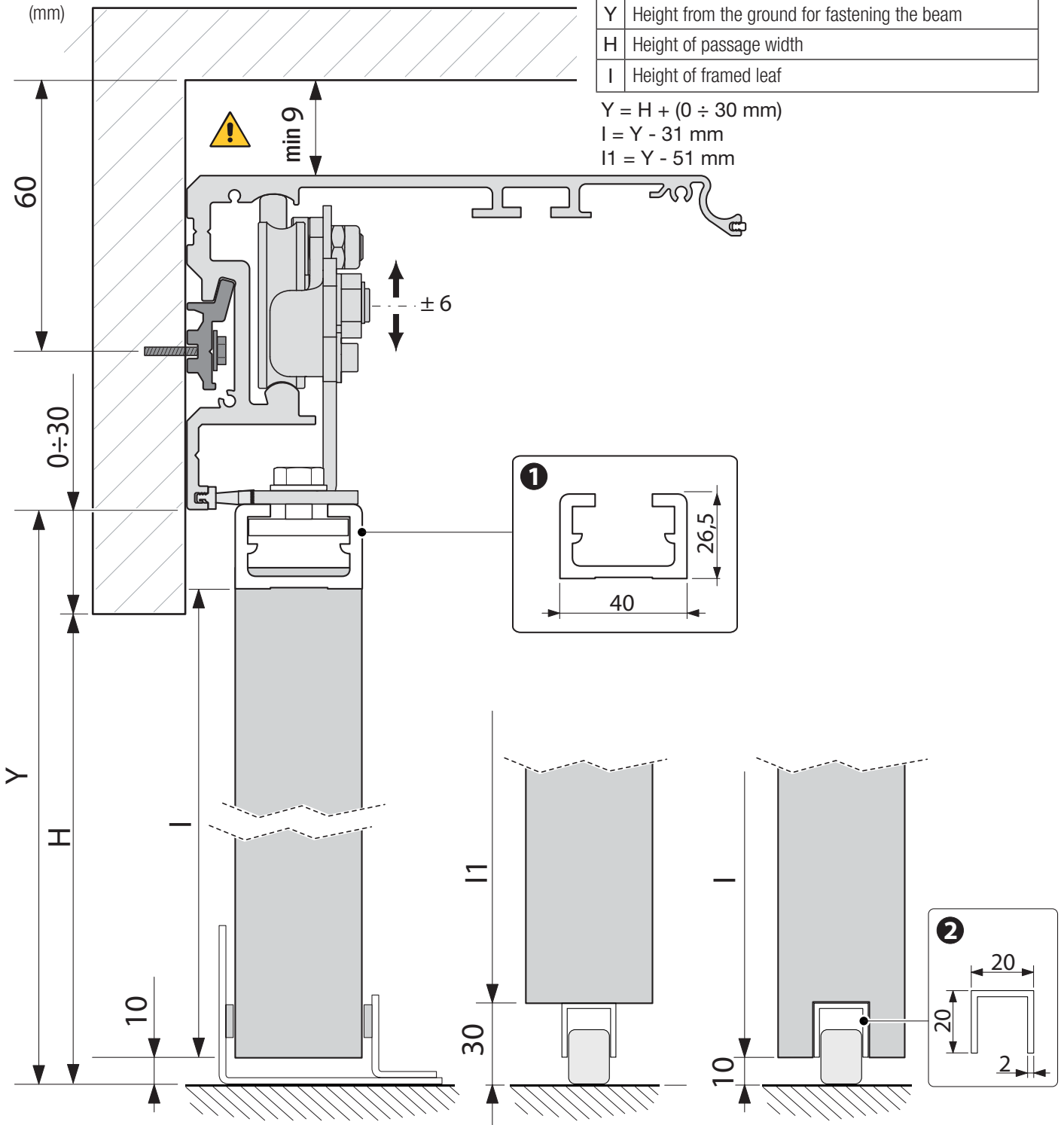

| | |
|---|---|
| Y | Height from the ground for fastening the beam |
| H | Height of passage width |
| I | Height of framed leaf |

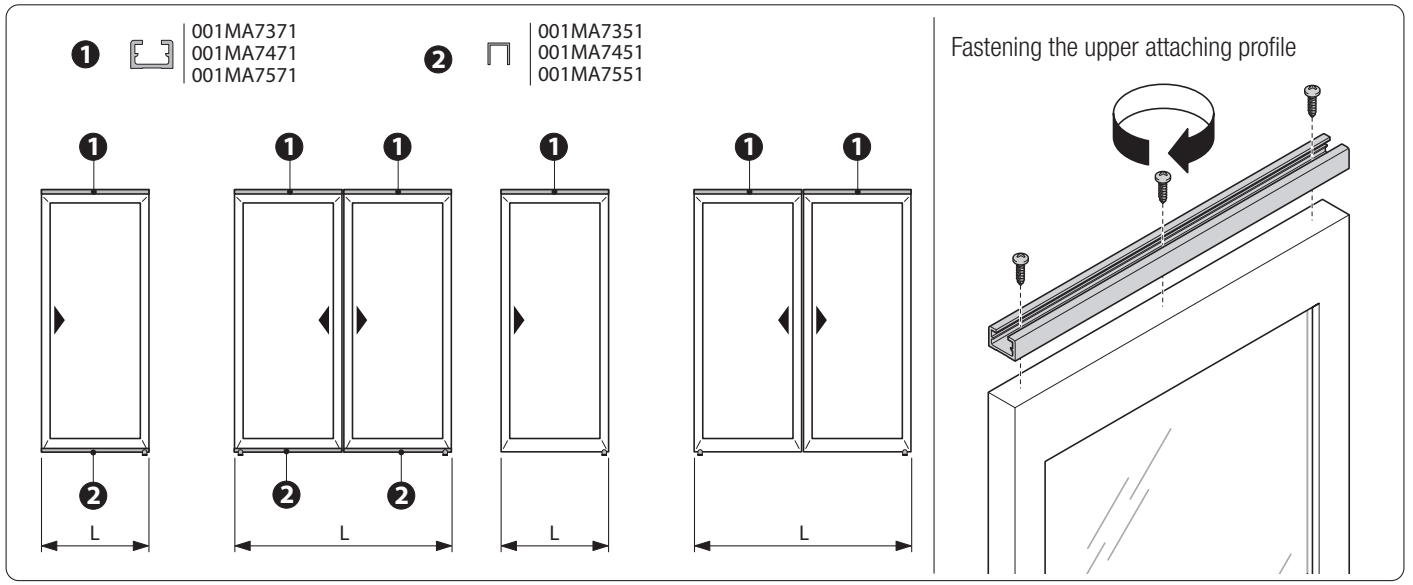
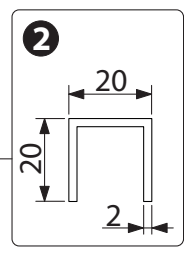
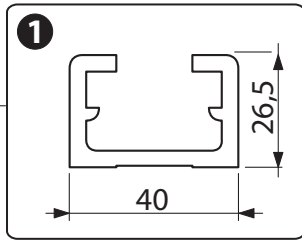

Fitting the carriages, the anti-derailing system and belt hook for TWO-LEAVED sliding doors

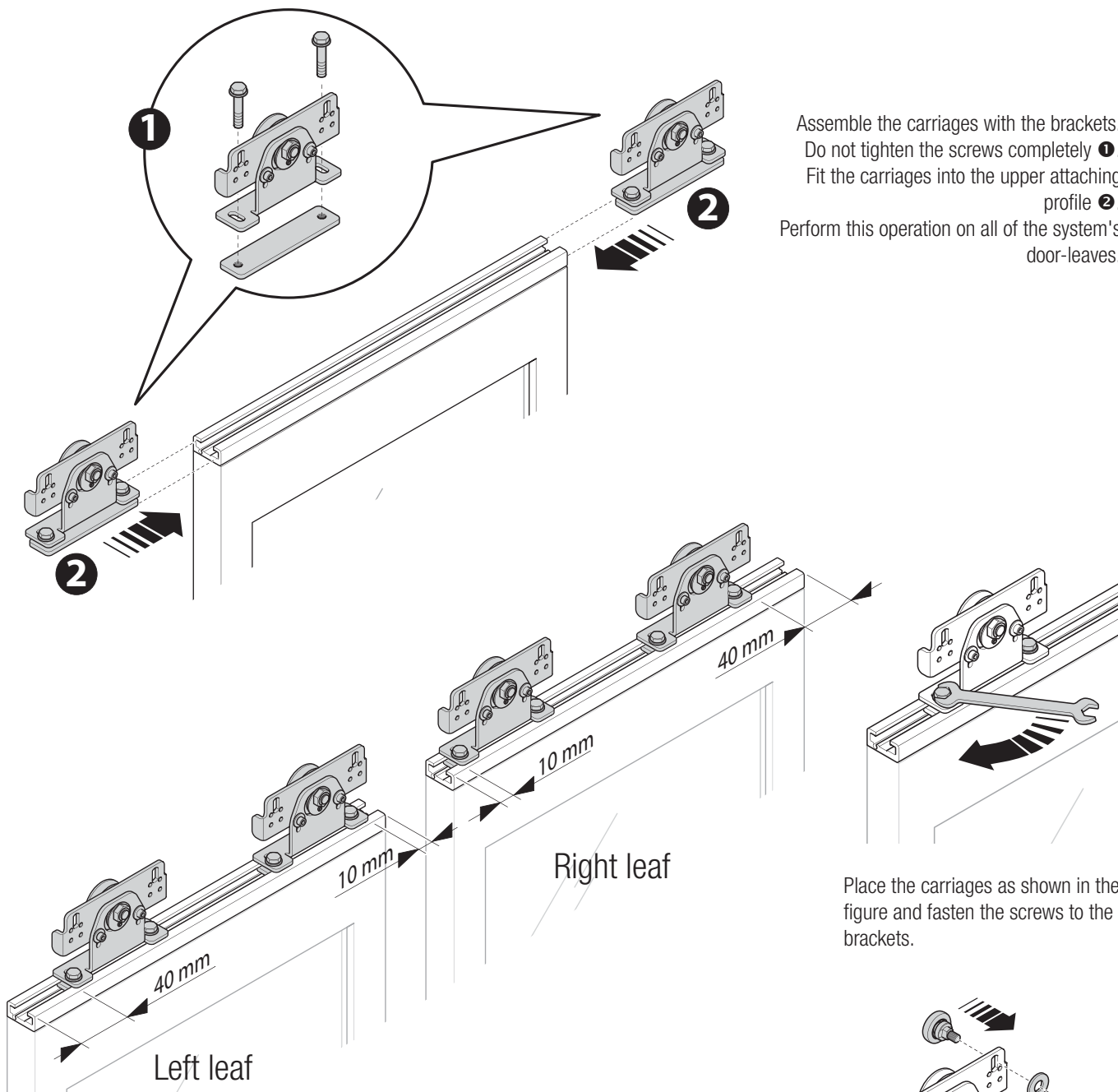

Assemble the carriages with the brackets.
Do not tighten the screws completely **1**.
Fit the carriages into the upper attaching profile **2**.
Perform this operation on all of the system's door-leaves.

Place the carriages as shown in the figure and fasten the screws to the brackets.

Fasten the anti-derailing device and the attaching bracket onto the carriages.
Leave the nuts loose.

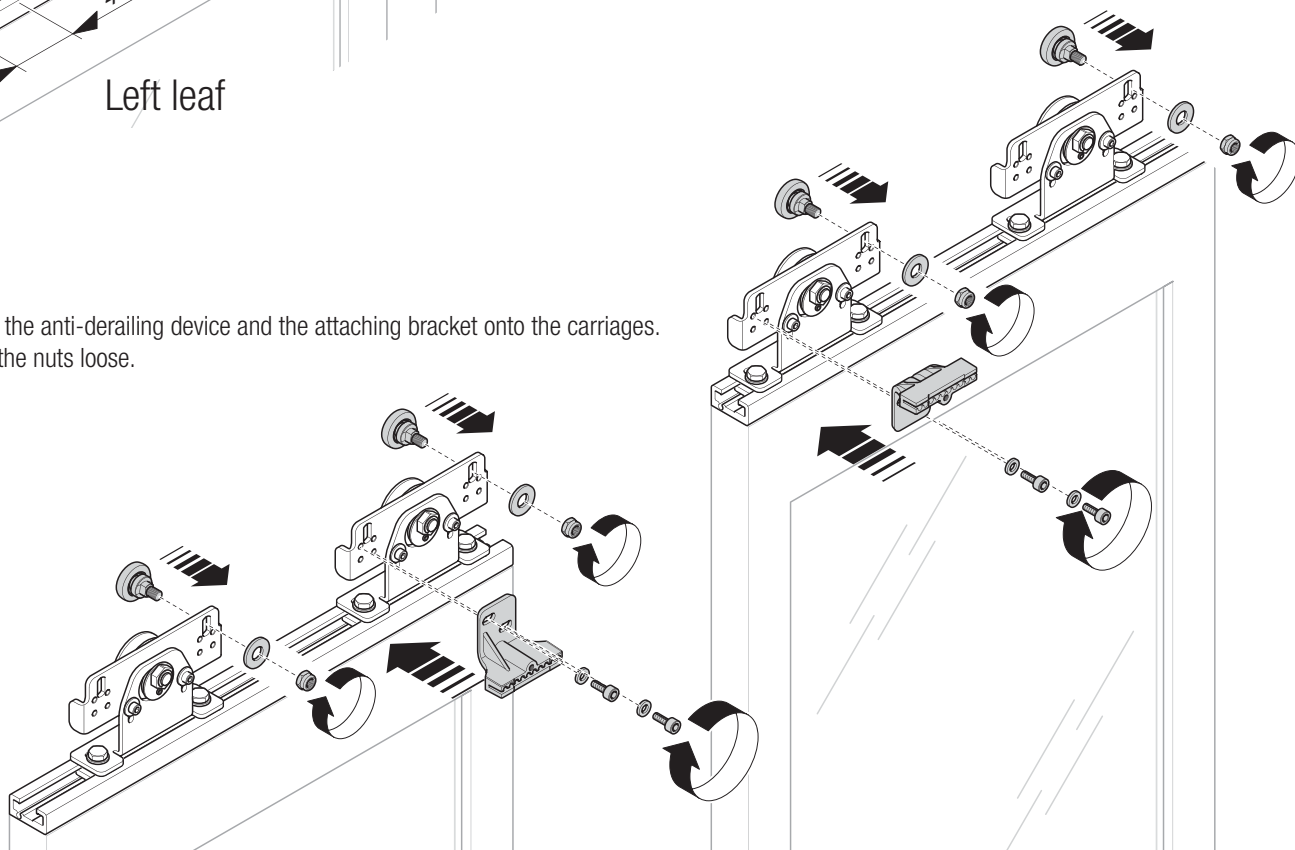

Fitting the carriages, anti-derailing system and belt attachment for ONE-LEAVED sliding doors

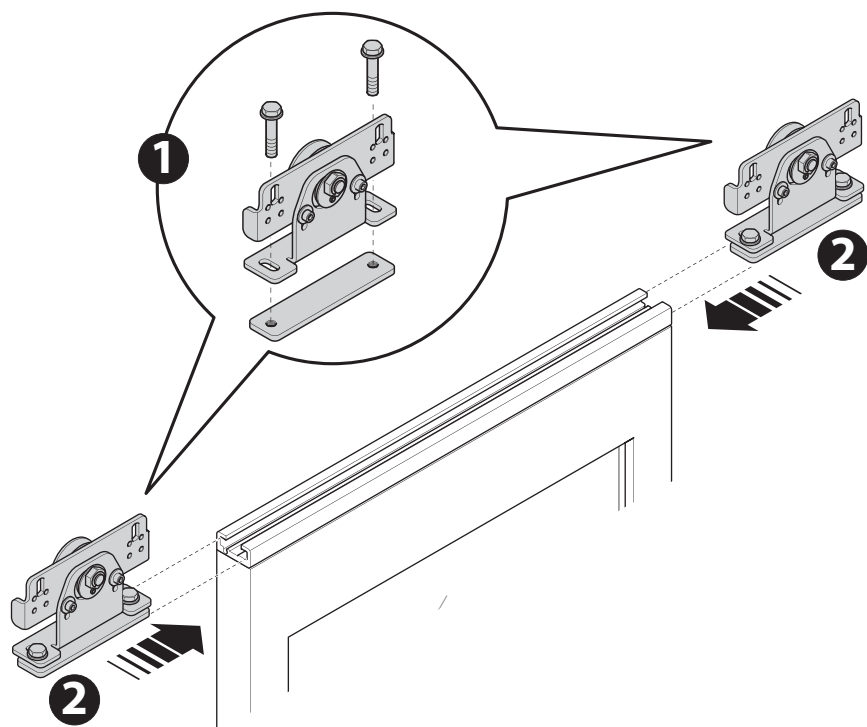

Assemble the carriages with the brackets.
Do not tighten the screws completely ❶.
Fit the carriages into the upper attaching profile ❷.
Perform this operation on all of the system's door-leaves.

Place the carriages as shown in the figure and fasten the screws to the brackets.

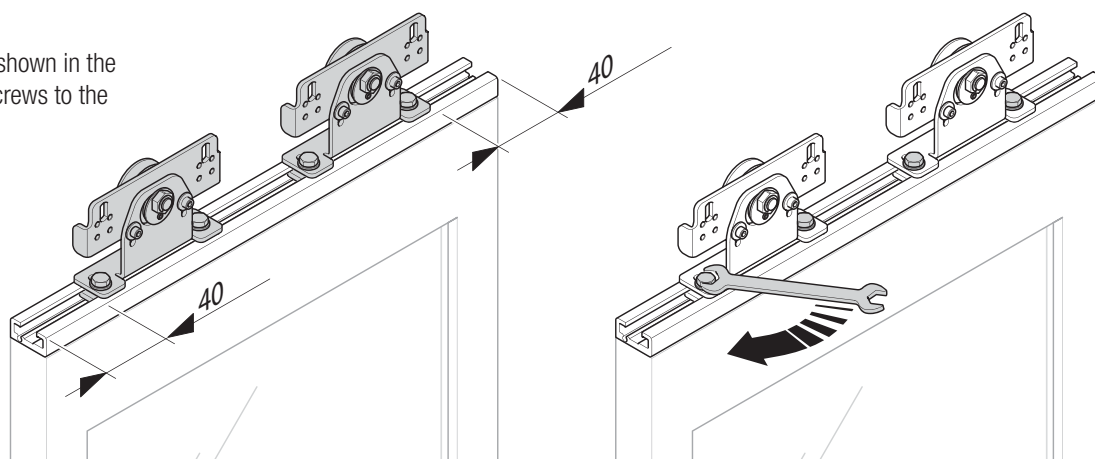

Fasten the anti-derailing device and the attaching bracket onto the carriages.
Leave the nuts loose.

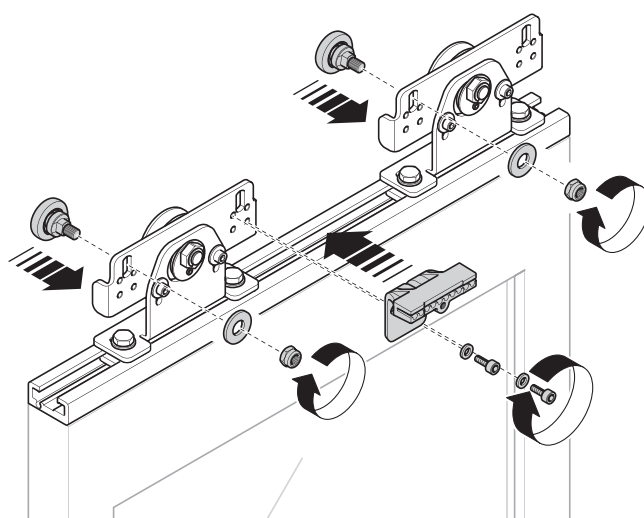

Fastening and aligning the leaves

 The following installation guidelines refer to a two-leaved system. You may adapt the guidelines to a one-leaved system.

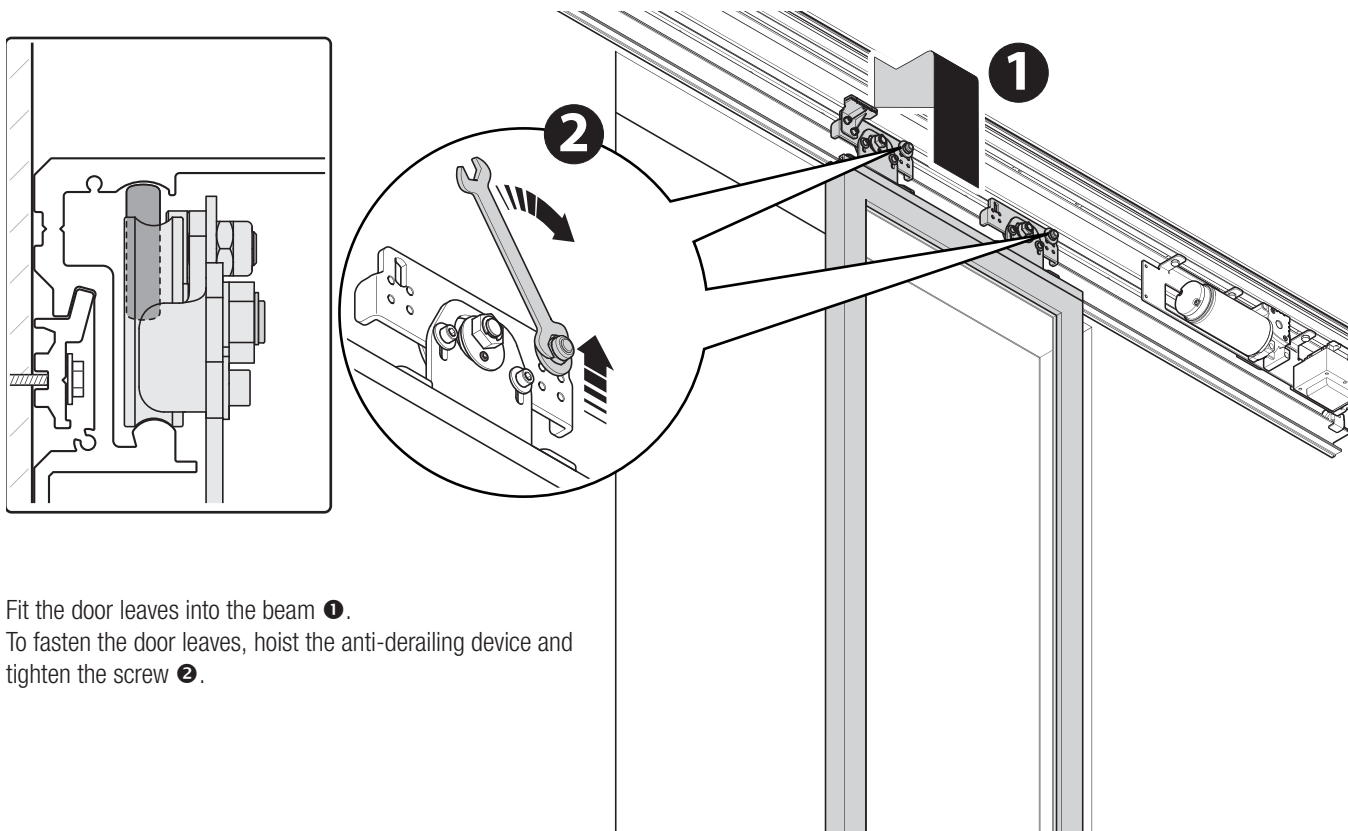

Fit the door leaves into the beam **1**.
To fasten the door leaves, hoist the anti-derailing device and tighten the screw **2**.

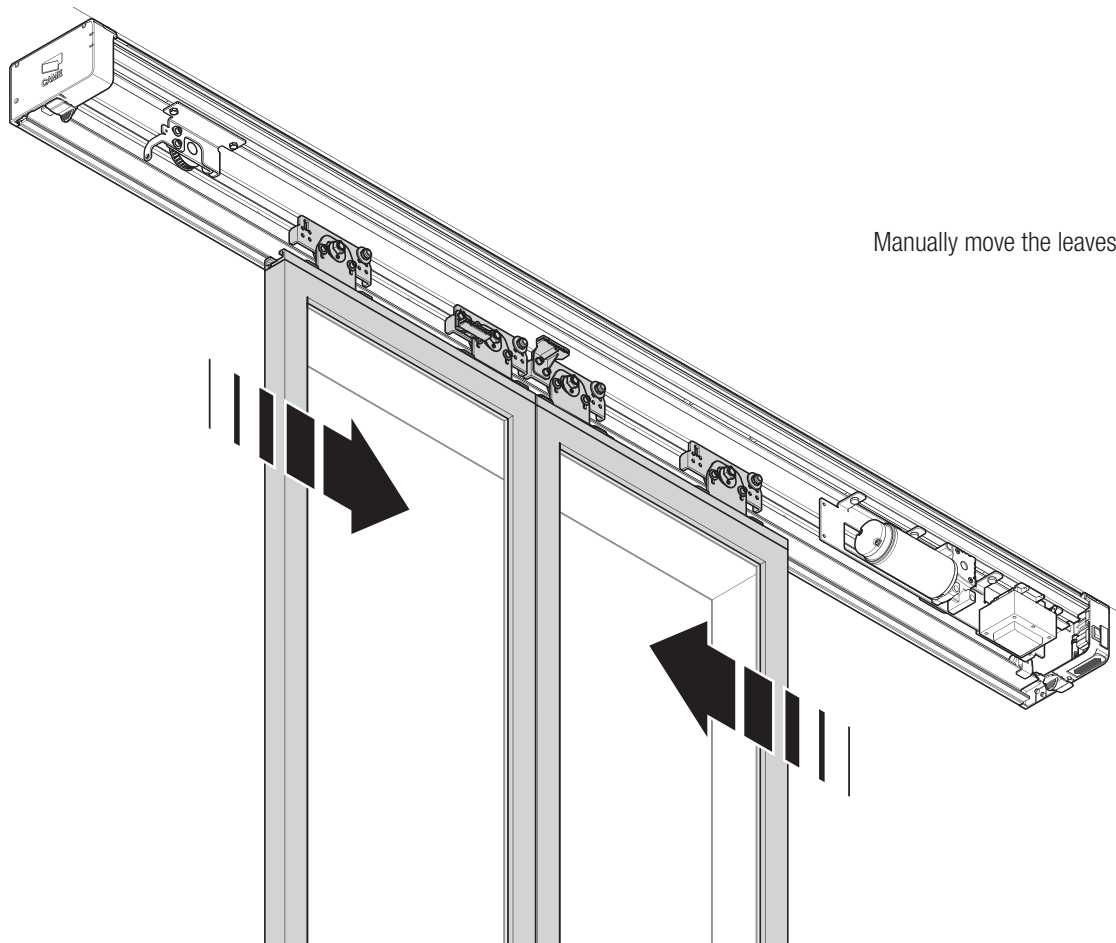

Manually move the leaves to the center.

Aligning 1

Check that the door leaves are level to ensure proper sliding along the rail **1**. If necessary, **2**, loosen the two roller screws **3**, adjust the inclination by turning the screw on the eccentric adjuster on each roller **4** **5**. Tighten the screws including the headless screw.

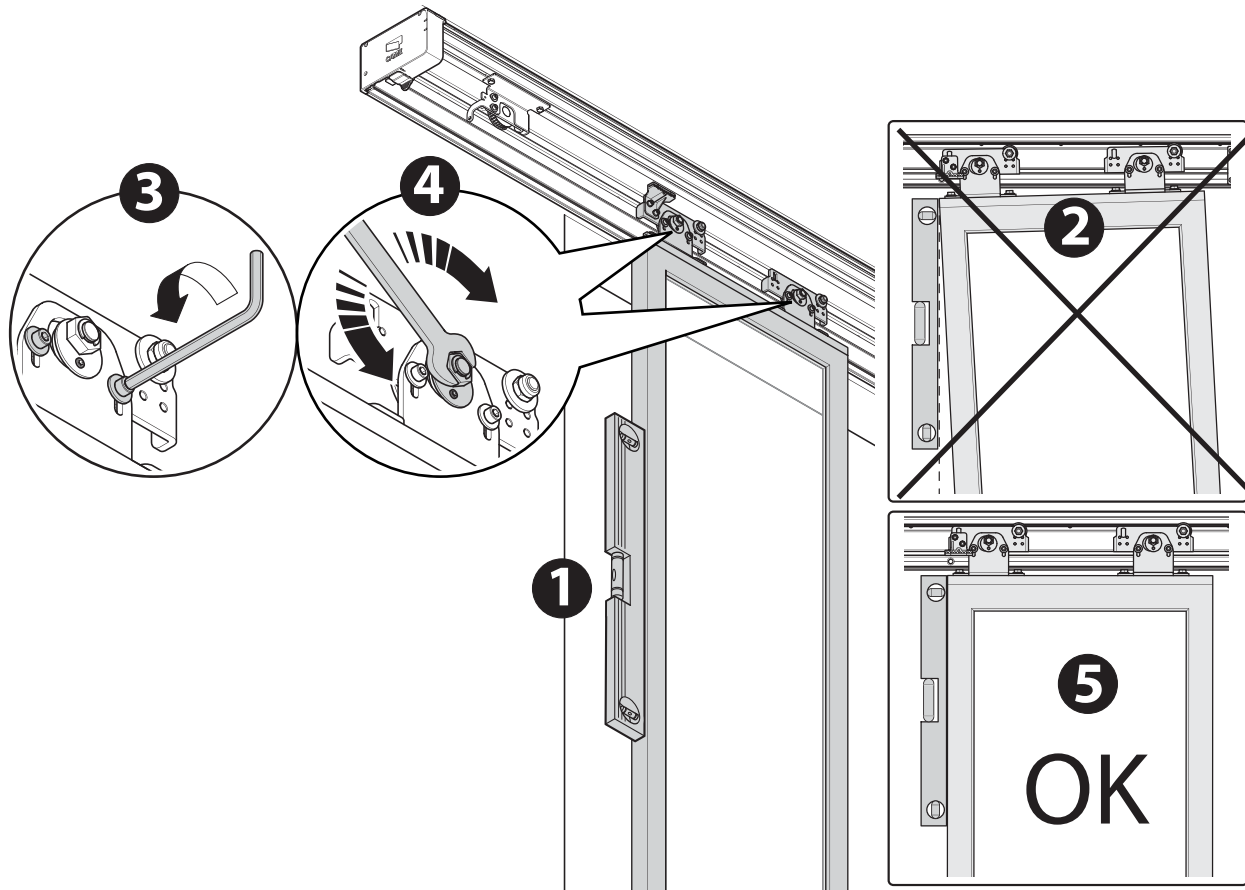

Aligning 2

If the two door leaves are not at the same height **1**, loosen the screws **2** and regulate the eccentric adjuster **3**. Lastly, tighten the screws including the headless screw.

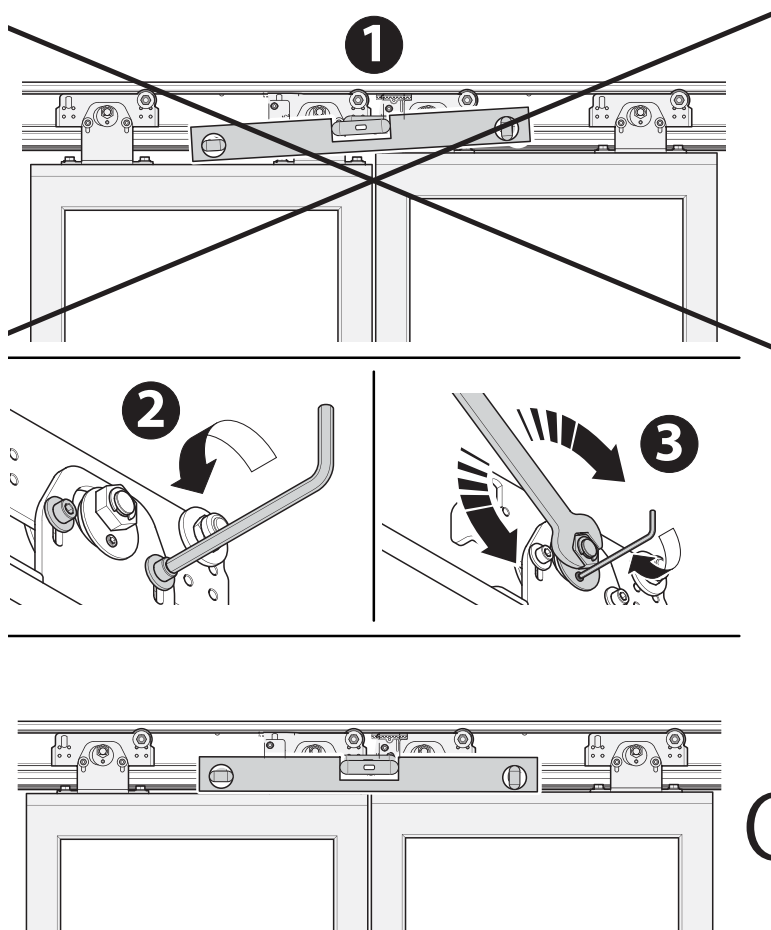

Aligning 3

If the door-leaves are not aligned **1** loosen the two hexagonal-head screws on each roller **2** and move the carriage back and forth **3**. Lastly, tighten the screws.

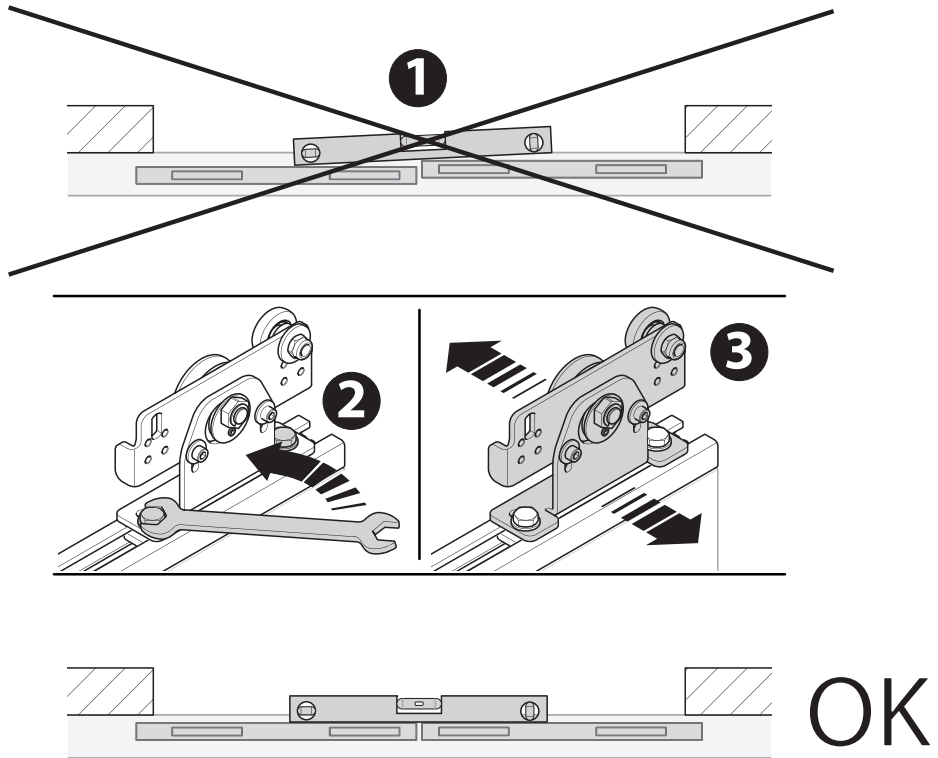

Fastening the slide guides.

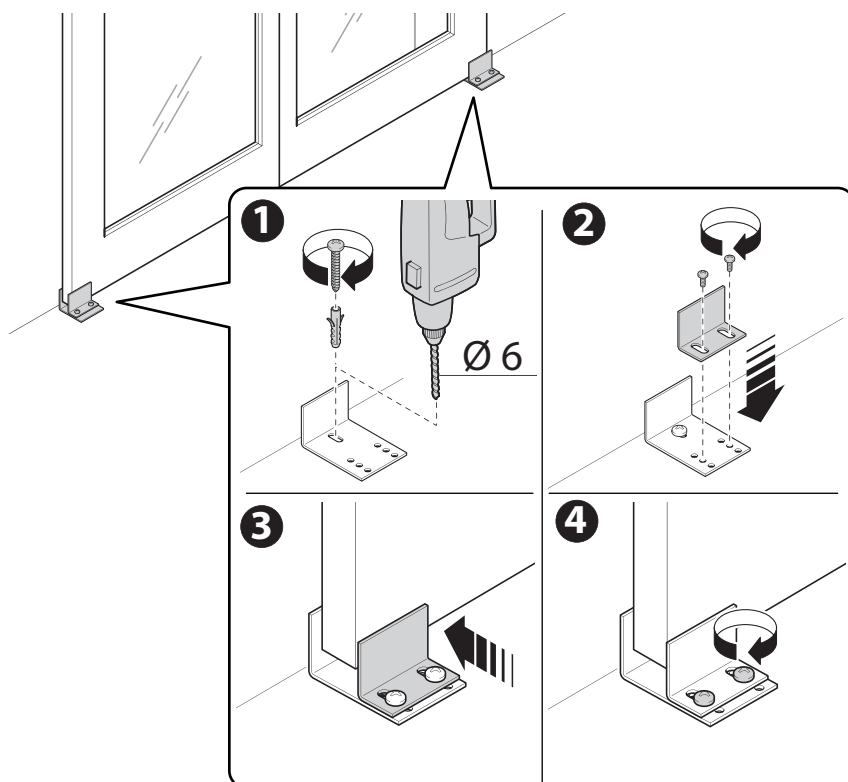

Fitting and fastening the belt

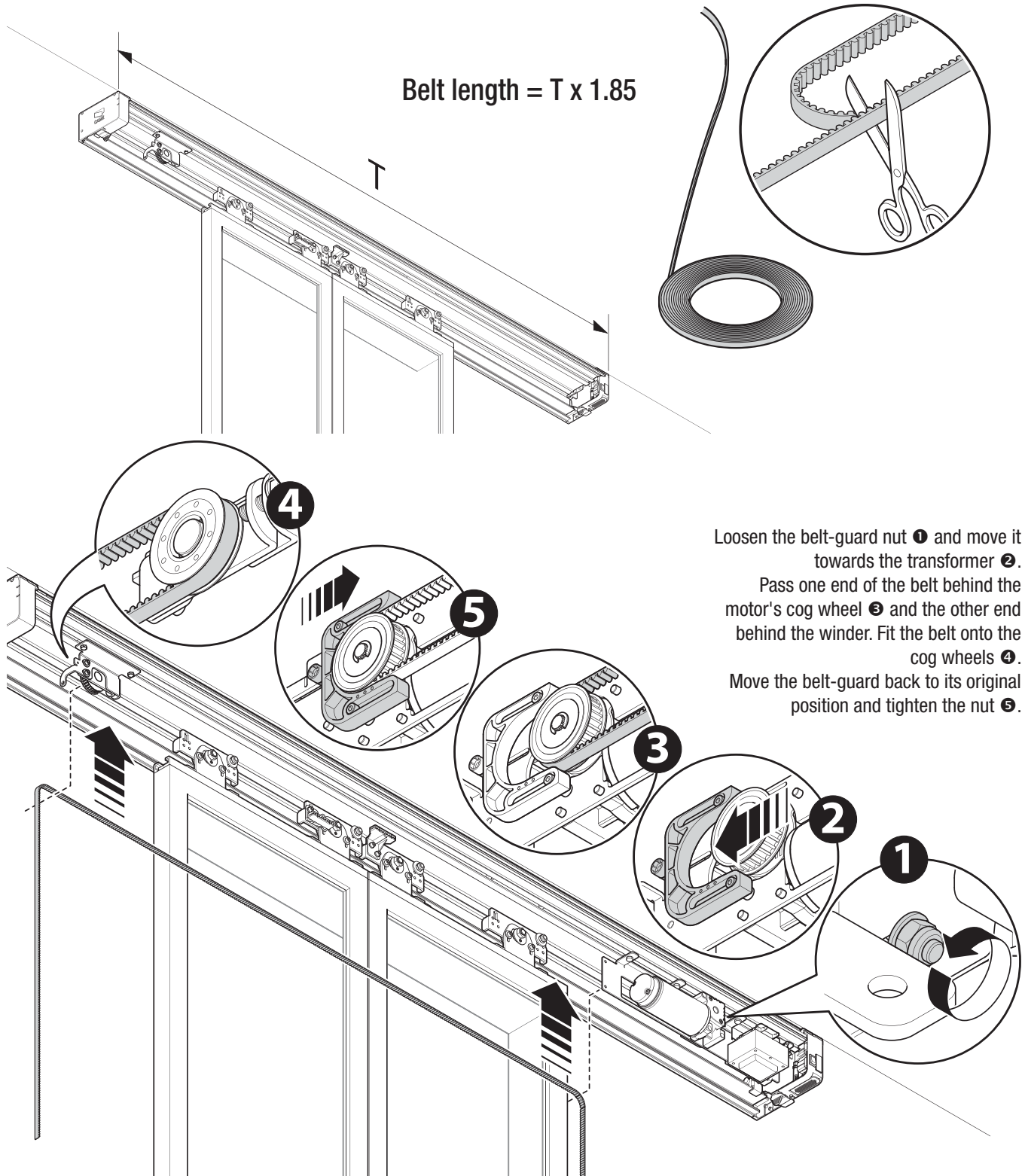

Fit the two ends of the belt onto the belt attaching bracket **1** and fasten it using the stop and screw **2**.

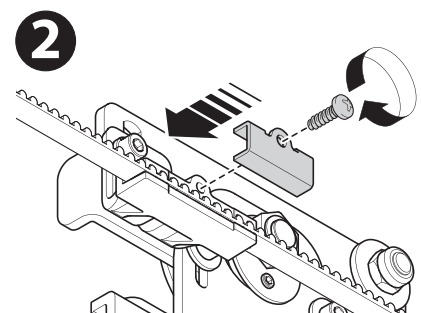
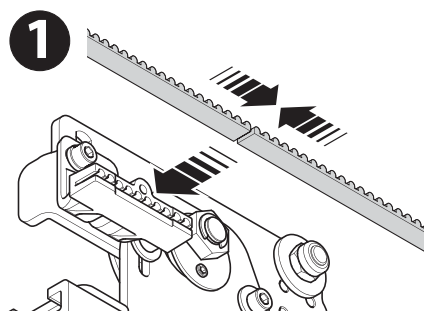

Adjusting belt-tension

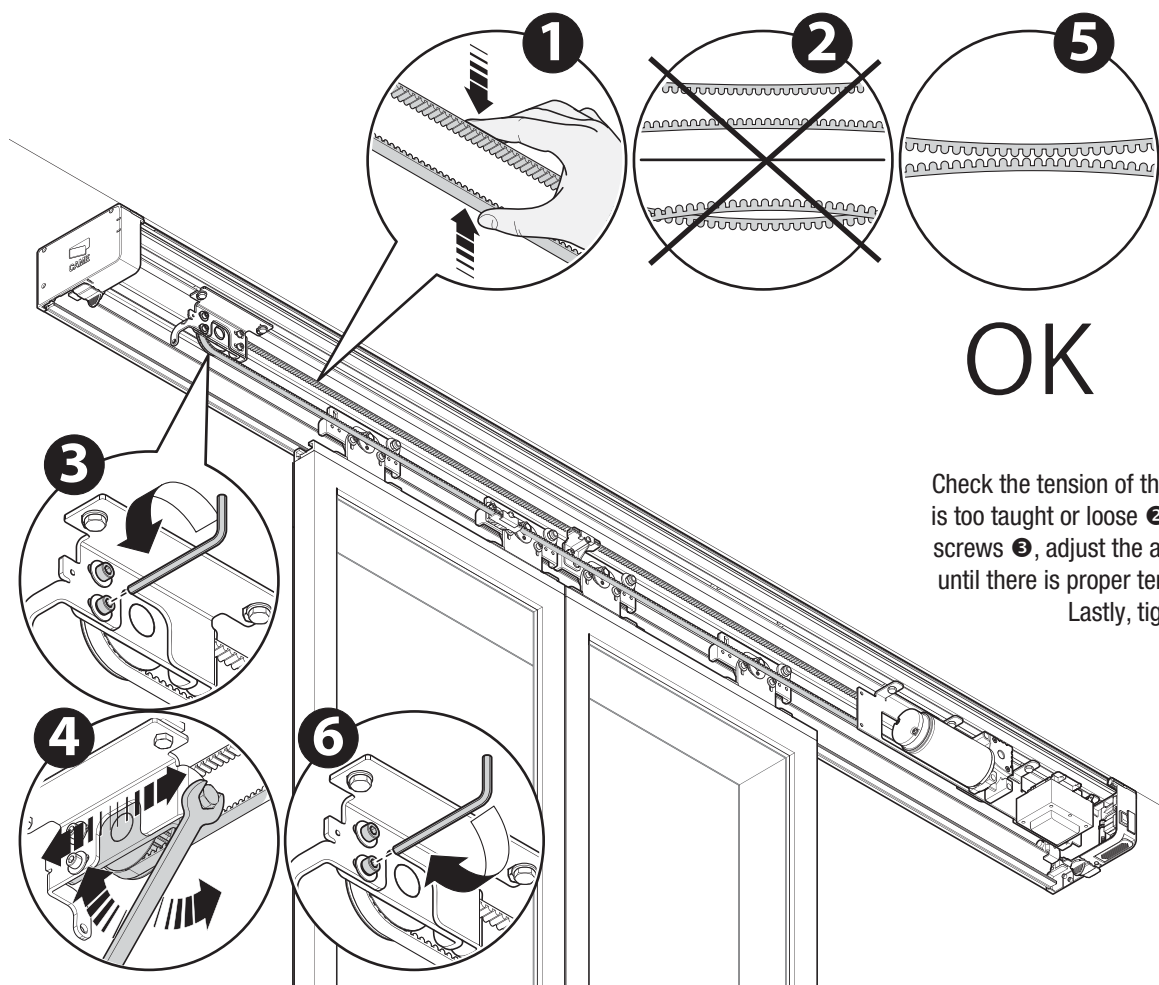

Check the tension of the belt **1**, whether it is too tight or loose **2**, loosen the winder screws **3**, adjust the adjustment screw **4** until there is proper tension on the belt **5**. Lastly, tighten the screws **6**.

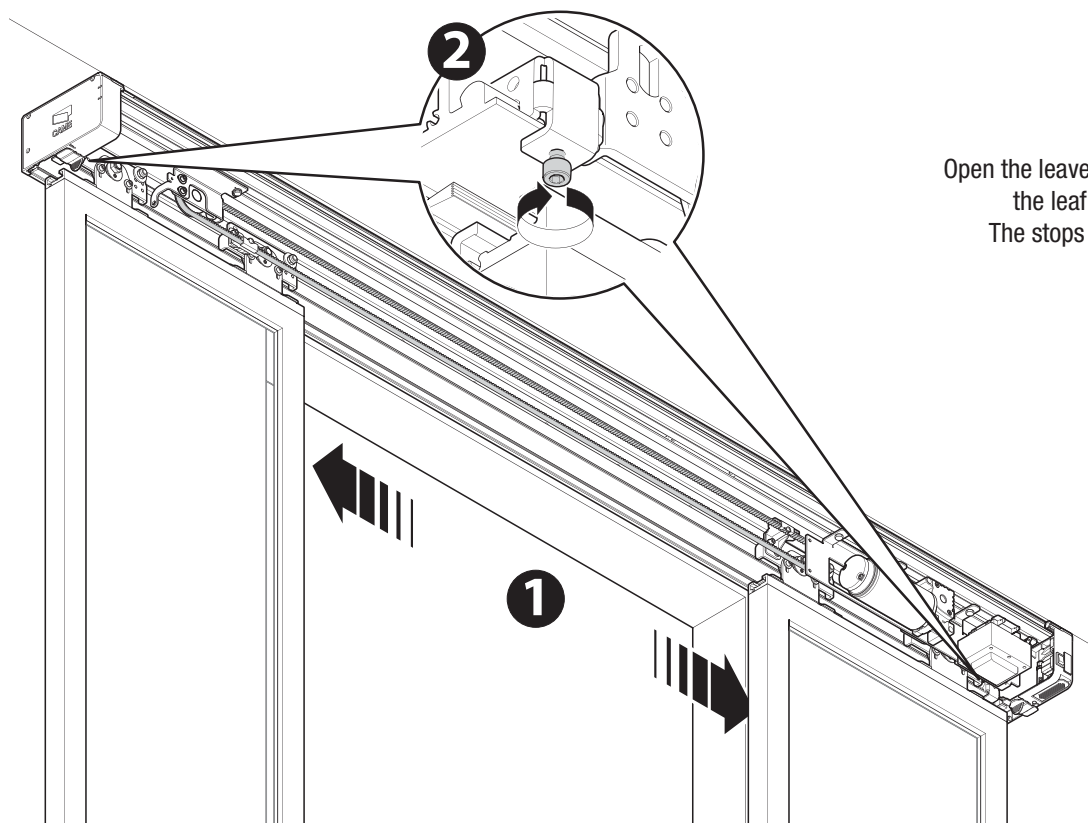

Open the leaves completely **1** and fasten the leaf stops using the screws **2**. The stops demarcate the full opening stop.

Fit the belt onto the other attaching bracket ❶ and fasten it using the stop and screw ❷.

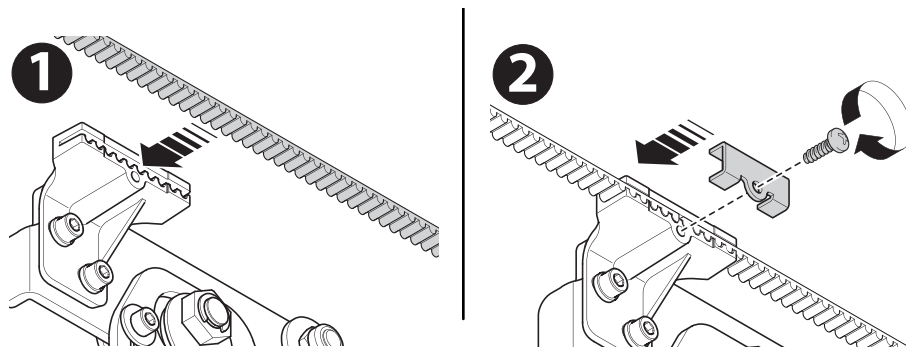

Fitting the control board assembly

Fasten the control board support onto the fastening bracket ❶ and onto the gearmotor assembly support ❷.

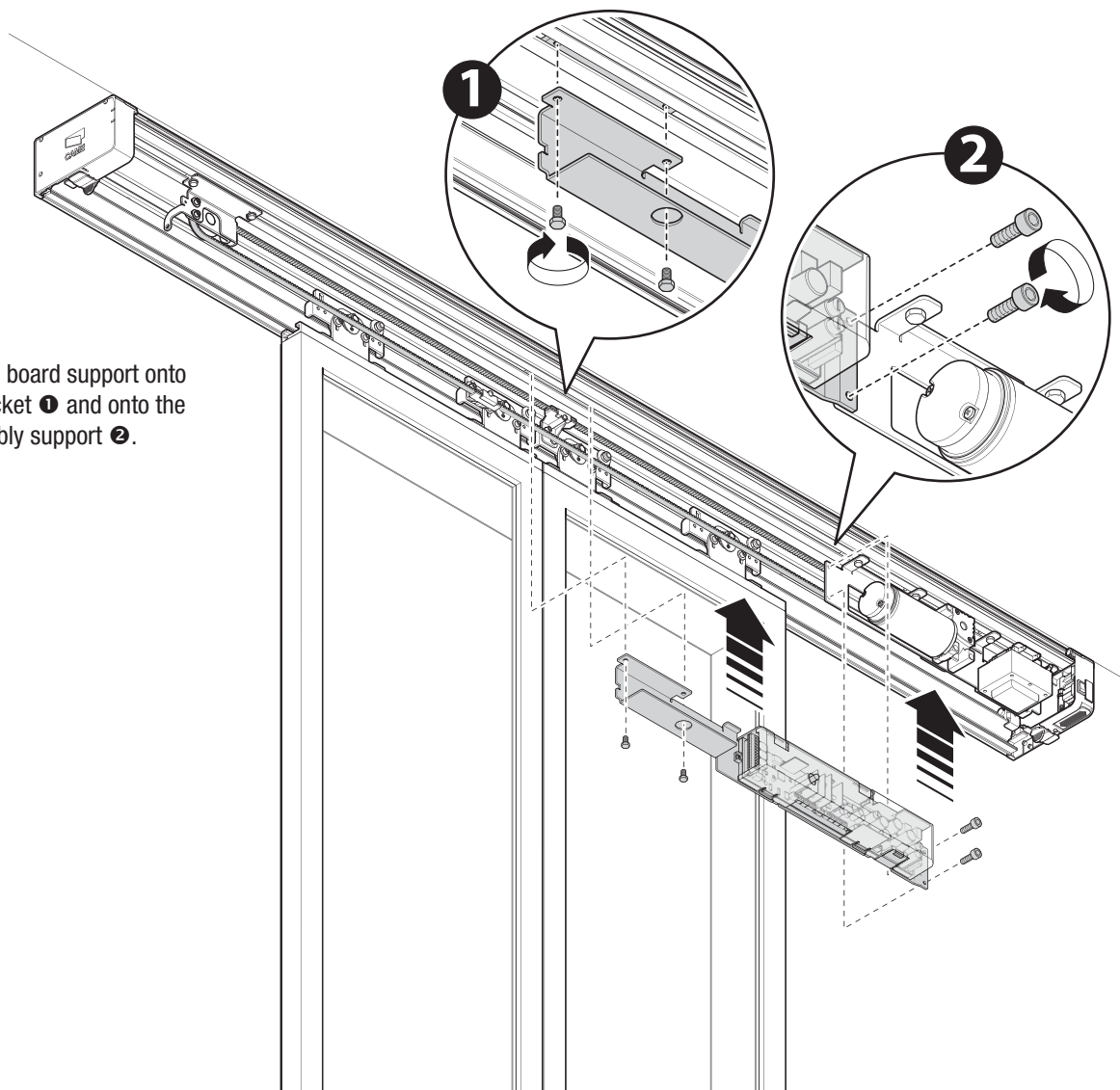

Assembling and fastening the profile covers

Fit the hinges between the two profile covers **1**.
Set up two for the ends (that are 25 mm from the edge) and a
enough for the central area.
 The distance between one hinge and the other must always be
identical.
Fasten the hinges with the screws **2**.

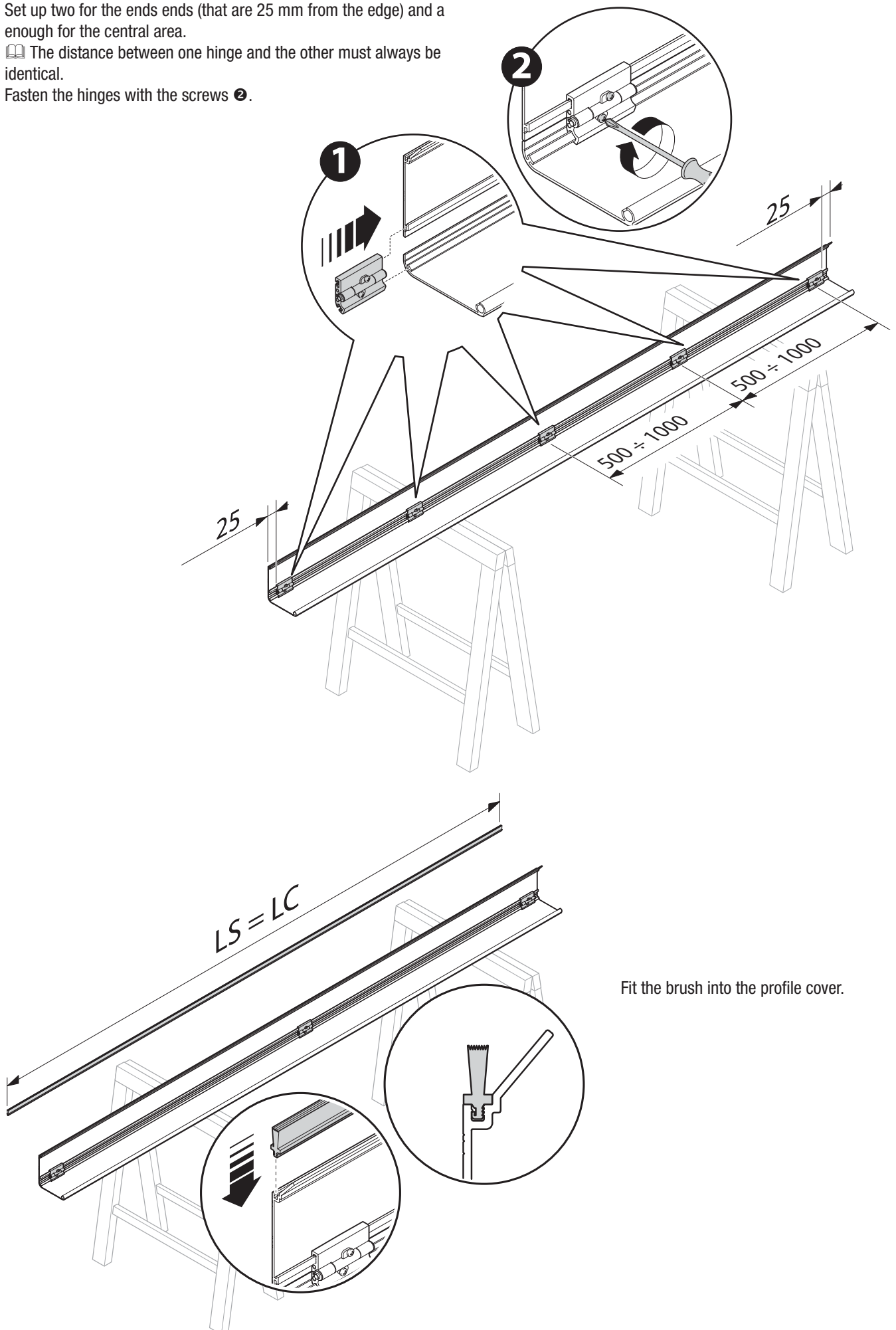

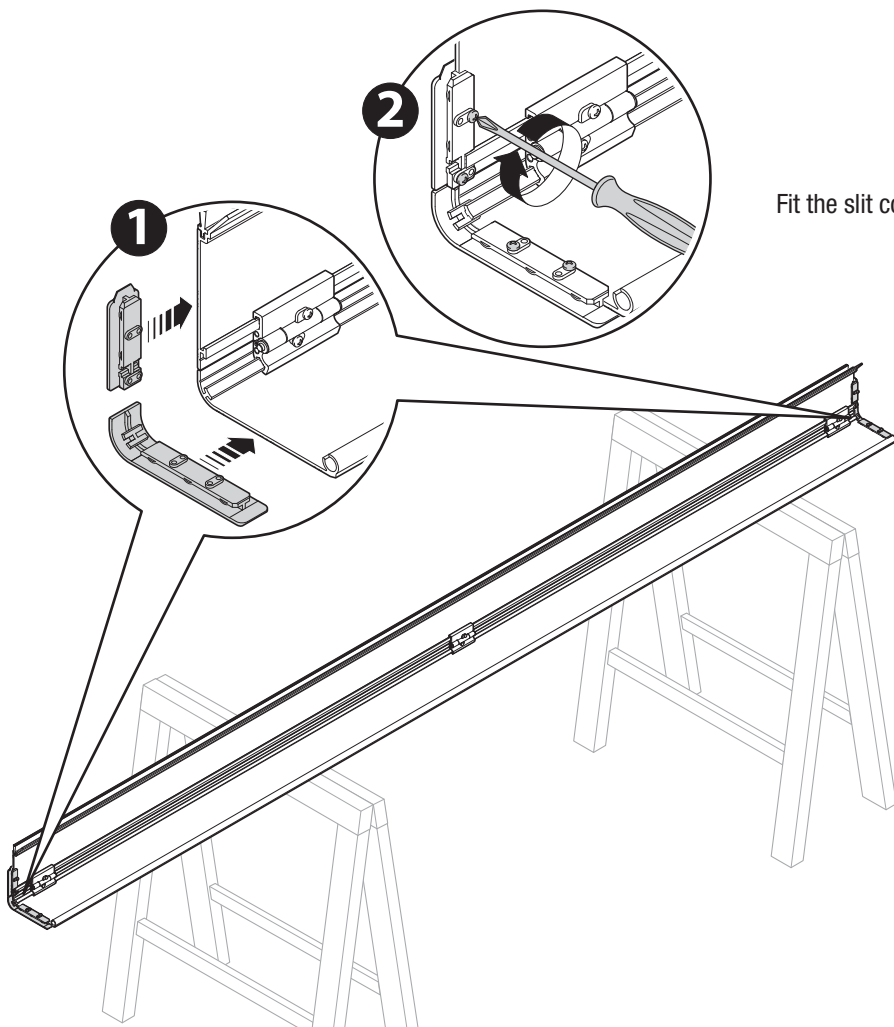

Fit the slit covers ❶ and fasten them using the screws ❷.

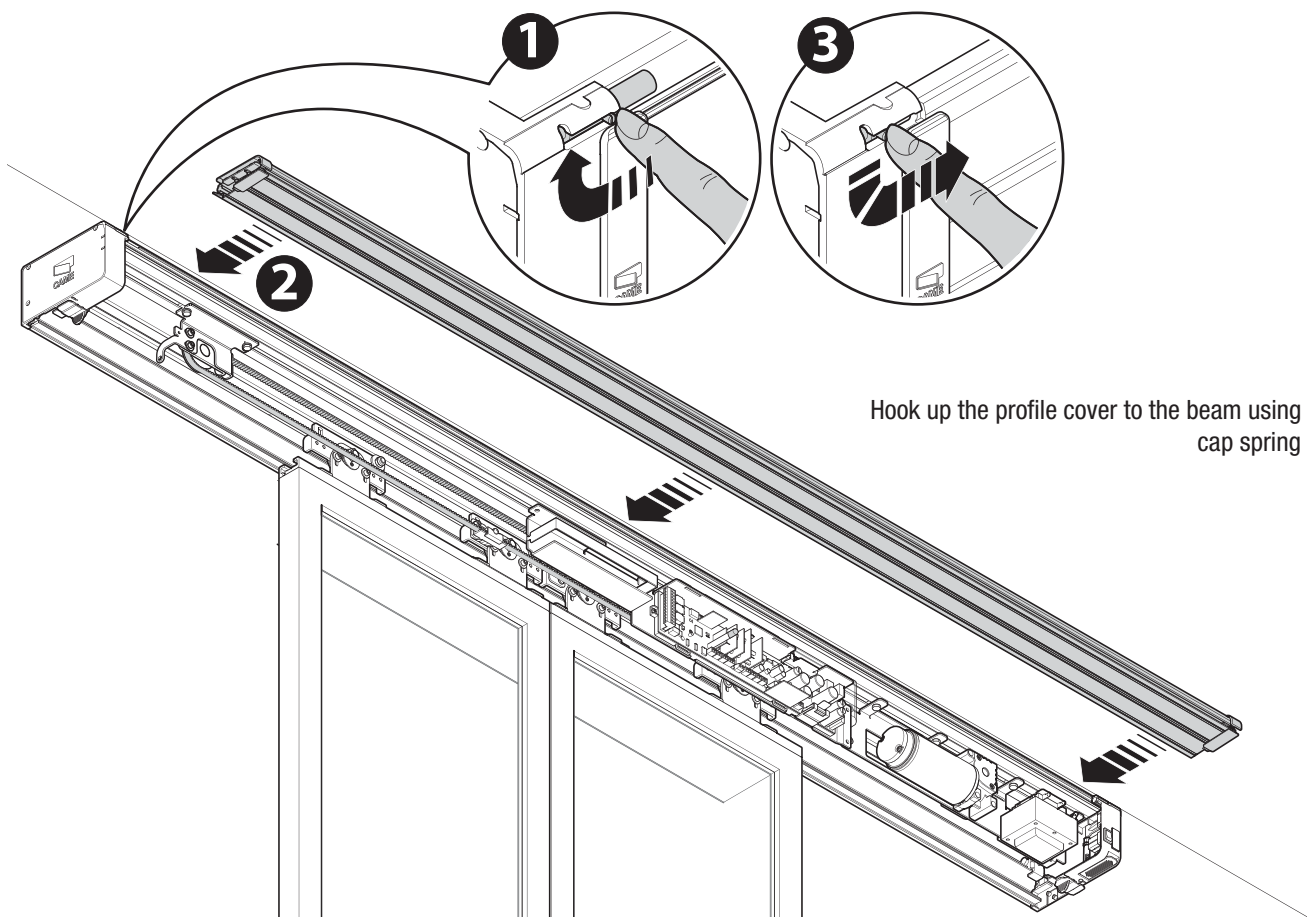

Hook up the profile cover to the beam using end-cap spring pins.

BOARD DESCRIPTION

- | | | |
|---|--|--|
| 1. Detection device terminals | 12. Battery fuse | 22. Keypad selector for sensor 1 terminals |
| 2. SIPA03 features selector terminals | 13. Gearmotor connector with encoder | 23. Antenna terminals |
| 3. Alternate or paired connection terminals | 14. Battery connector | 24. Photocell terminals |
| 4. DIP-SWITCH | 15. 24 V AC card power supply connector | 25. Antipanic system photocell terminals |
| 5. SIPA06 clock card connector | 16. Line fuse | 26. Antenna connector for SIPA04 |
| 6. Reset button | 17. Socket for terminal with bridge for connecting batteries | 27. Green LED |
| 7. RFPA SIPA05 card connector | 18. LBPA SIPA01 card connectors | 28. Red LED |
| 8. DOCP1 SIPA08/09 card connector | 19. TSP00 transponder for sensor 2 terminals | 29. CRP connection terminals |
| 9. AF/R700/R800 for sensor 1 card connector | 20. keypad selector for sensor 2 terminals | |
| 10. R700/R800 for sensor 2 card connector | 21. TSP00 transponder for sensor 1 terminals | |
| 11. Accessories fuse | | |

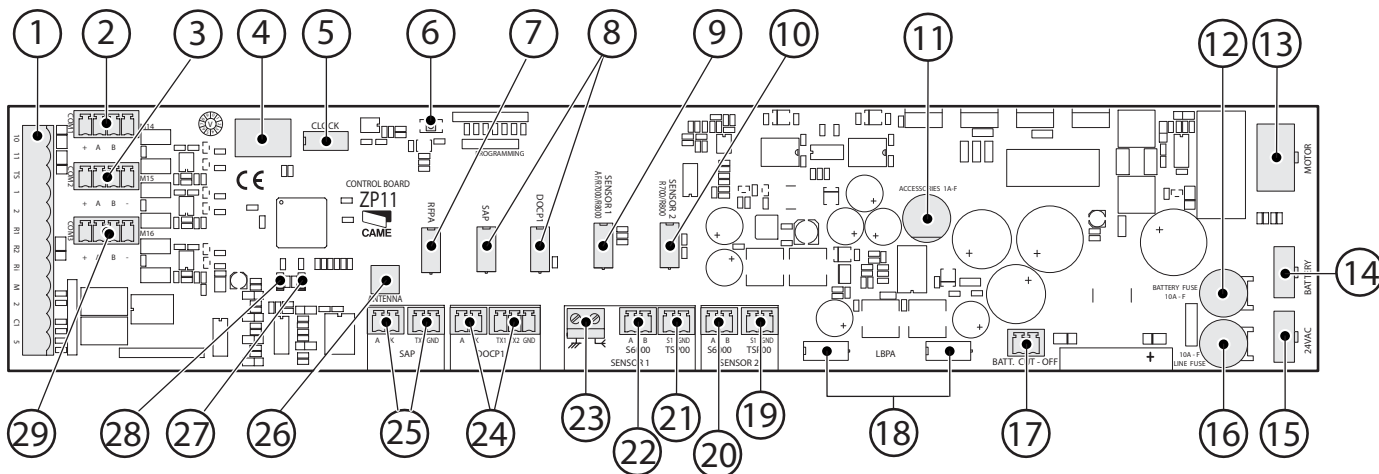

Electrical connections

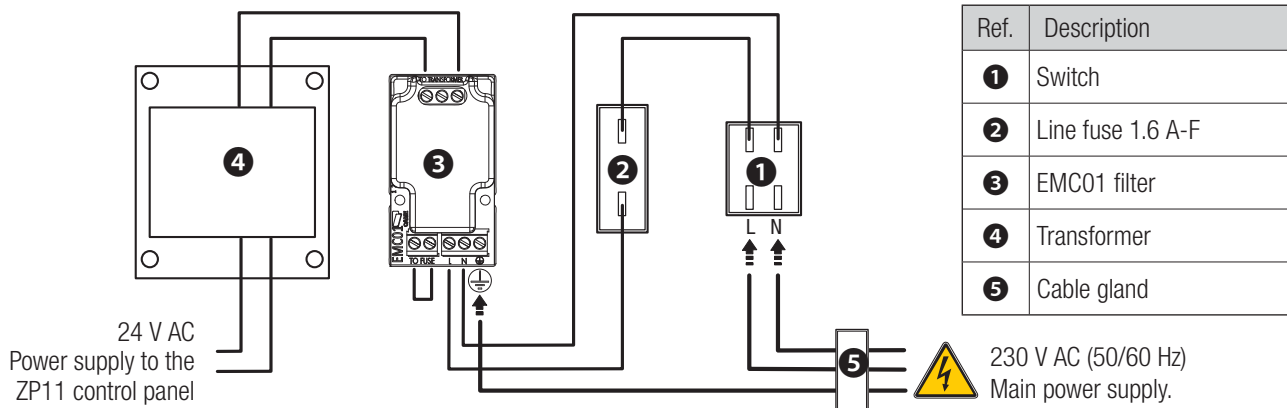

| Ref. | Description |
|------|--|
| (N) | Neutral |
| (F) | Ground |
| (⊕) | Line |
| 1 | Power supply to transformer 230 V AC (red cable) |
| 2 | Power supply to transformer 120 V AC (black cable) |
| 3 | Power supply to transformer 0 V AC (white cable) |

POWER SUPPLY AT 230 V AC (Factory configuration)

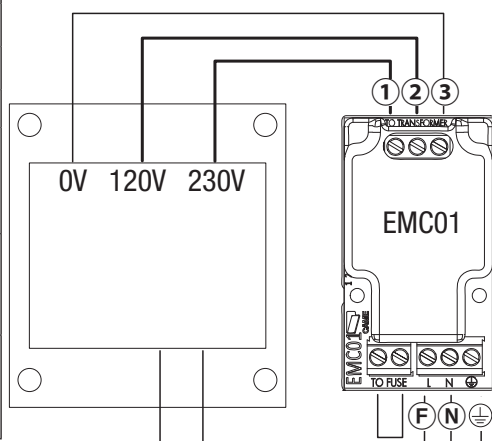

POWER SUPPLY AT 120 V AC (invert cables 1 and 2 as shown)

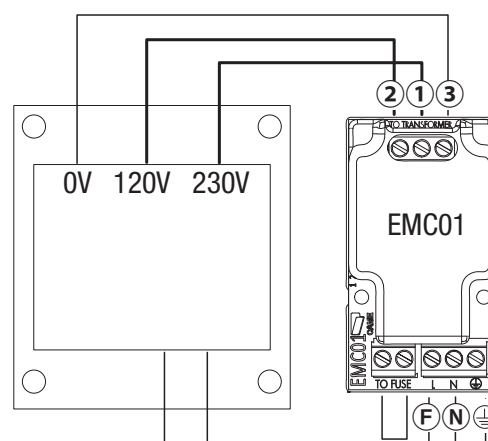

Connecting accessories

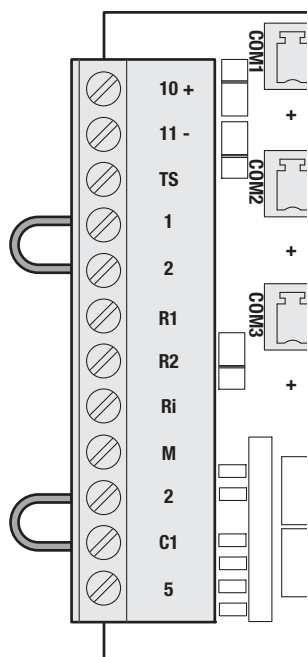

- 10 - 11** 12 V DC accessories power supply output
Careful! The accessories connected to 10-11 must not exceed 18 W overall
- TS** Photocells safety connection (services test)
- 1 - 2** STOP (N.C.) button connection
The contact is bridged. If necessary, remove the bridge.
- 2 - R1** Outer sensor (N.O.) connection (excludable)
- 2 - R2** Inner sensor connection (N.O.)
- 2 - Ri** Central interlock (N.O.) connection (only with alternate mode)
- 2 - M** Manual opening/closing control (N.O.)
The contact has two functions:
 - Opening command, even if with SIPA04 or SIPA03 in CLOSED DOOR mode, for preferential passage (e.g. evening closing, opening via key-switch or magnetic selectors).
 - STEP-BY-STEP OPENING with manual or alternating mode with AUTOMATIC CLOSING disabled; pressing the button opens the door leaf completely which then closes only if the door leaf is completely open.
 With this feature contacts 2-R1 and 2-R2 are excluded.
- 2 - C1** Reopening during closing photocells connection (N.C.) (excludable).
The contact is bridged. If necessary, remove the bridge.
The contact is used for photocells or other safety devices, whenever it is not possible to use the dedicated socket.
- 5 - 10** Door open warning light

Selecting features via DIP-switches

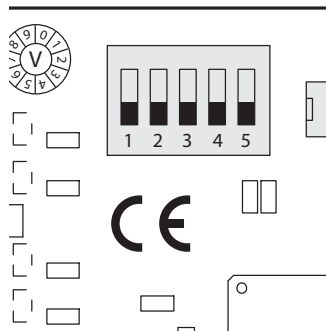

| DIP-SWITCH | Description of features |
|------------|---|
| 1 ON | Door-travel calibration |
| 1 OFF | Normal operation |
| 2 ON | The board becomes MASTER when operating in alternate or paired mode |
| 2 OFF | The card becomes SLAVE when working in the alternating or paired mode Normal operation |
| 3 ON | Alternating mode operation (only on MASTER) |
| 3 OFF | Paired operation (only on MASTER) Normal operation |
| 4 ON | Recording SIPA04 (if present) |
| 4 OFF | |
| 5 ON | Door-leaf opens towards LEFT |
| 5 OFF | Door-leaf opens towards RIGHT Double-leaf door opening |

 This feature can be set even via the SIPA03 or SIPA04

Accessories connection

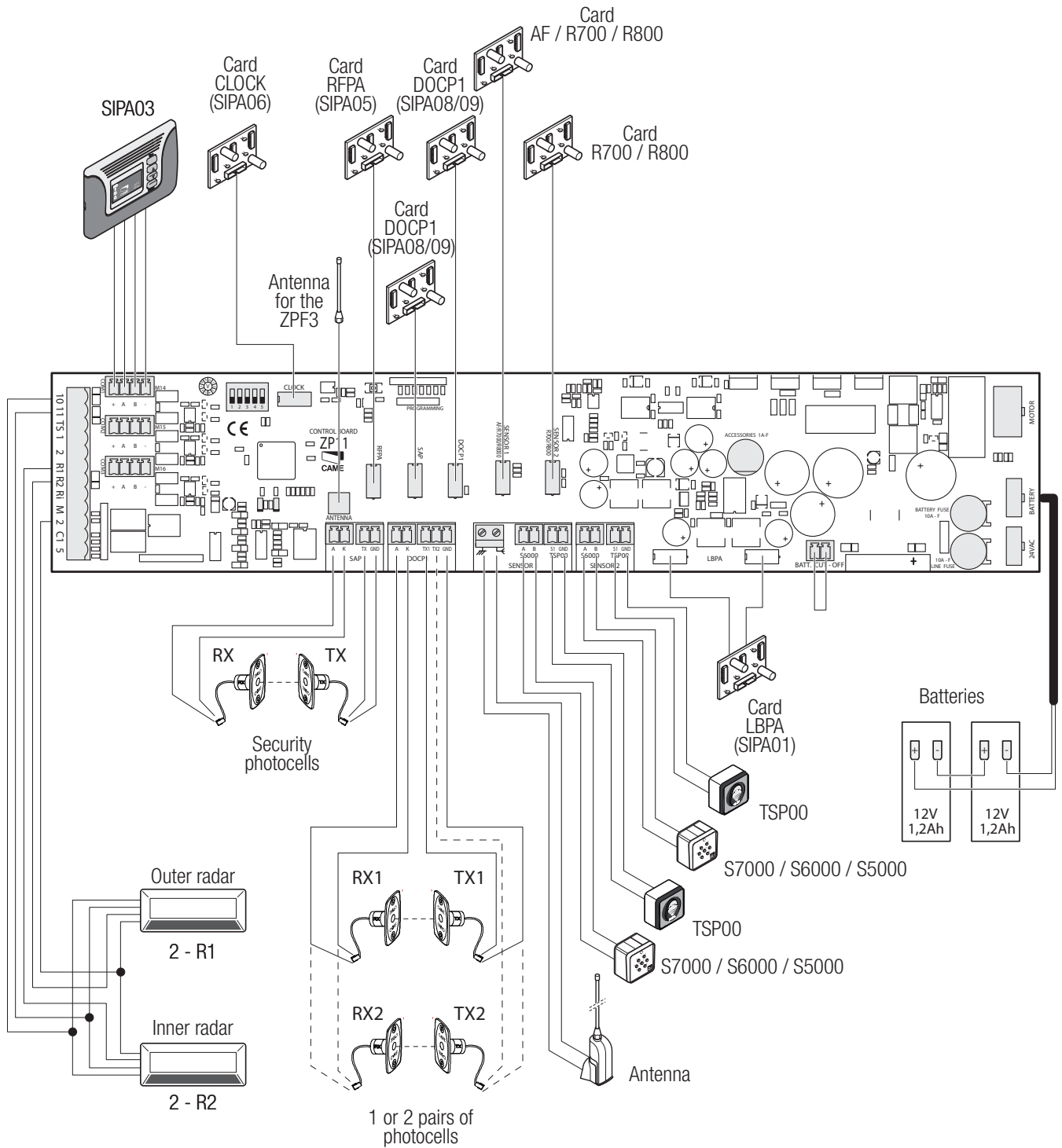

LED table

| | | |
|---------------------------|---------------------------|--|
| Green LED | ○ OFF | No power supply |
| | ☀ 4 flashes per second | STOP (1-2) contact is open or contact is open on photocells |
| | ☀ Turned on steady | Calibrated and working normally |
| Red LED | ☀ 1 flash per second | Automatic closing count |
| | ☀ 2 flashes per second | Automatic closing count after detecting an obstruction while closing |
| | ☀ 4 flashes per second | Obstruction detection |
| | ☀ Turned on steady | Automatic closing time renewal |
| Green and Red LEDs | ☀ Flashing intermittently | The door travel calibration was not done |

Travel calibration

Preliminary checks

Check that:

- The belt is properly taut;
- There are no obstructions along the door-leaves travel;
- That all the screws are tightened;
- That the sensors are properly aligned and unobstructed;
- That the desired features are properly set on the Dip-switches;
- That the STOP 1-2 contact is closed;
- The door-leaves are half-way along their travel.

Important! During calibration, all safety devices shall be disabled until calibration is finished, except for the TOTAL STOP.

Set Dip-switch 5 to the required position and power-up the operator.

The green and red LEDs flash intermittently.

With the SIPA03 or SIPA04, check that the AUTOMATIC mode is selected.

Set Dip-switch 1 to ON.

The door leaves will perform a closing and opening maneuver. Then the operator will place itself at the maximum opening point (the green LED stays on steady).

Set Dip-switch 1 to OFF.

Give an opening command. The operator will close.

Give an opening command. The operator will perform an opening and a closing maneuver.

Safety feature

When the safety device detects an obstruction, the control board commands,

- a reopening** if the operator is closing
- a stop** if the operator is closing.

If the obstruction remains,

- when closing** the operator carries out three closing attempts and then stops open waiting for a new command
- when opening** the operator stops at the obstruction and activates the automatic closing.

(once the obstruction is removed, normal operation is automatically restored).

ALTERNATING SYSTEM

- 1 Photocells
- 2 ZP11 control board
- 3 001SIPA02 Electroblock
- 4 Control radar
- 5 SIPA03 Features Selector
- 6 Detection radar
- 7 Presence detection zone

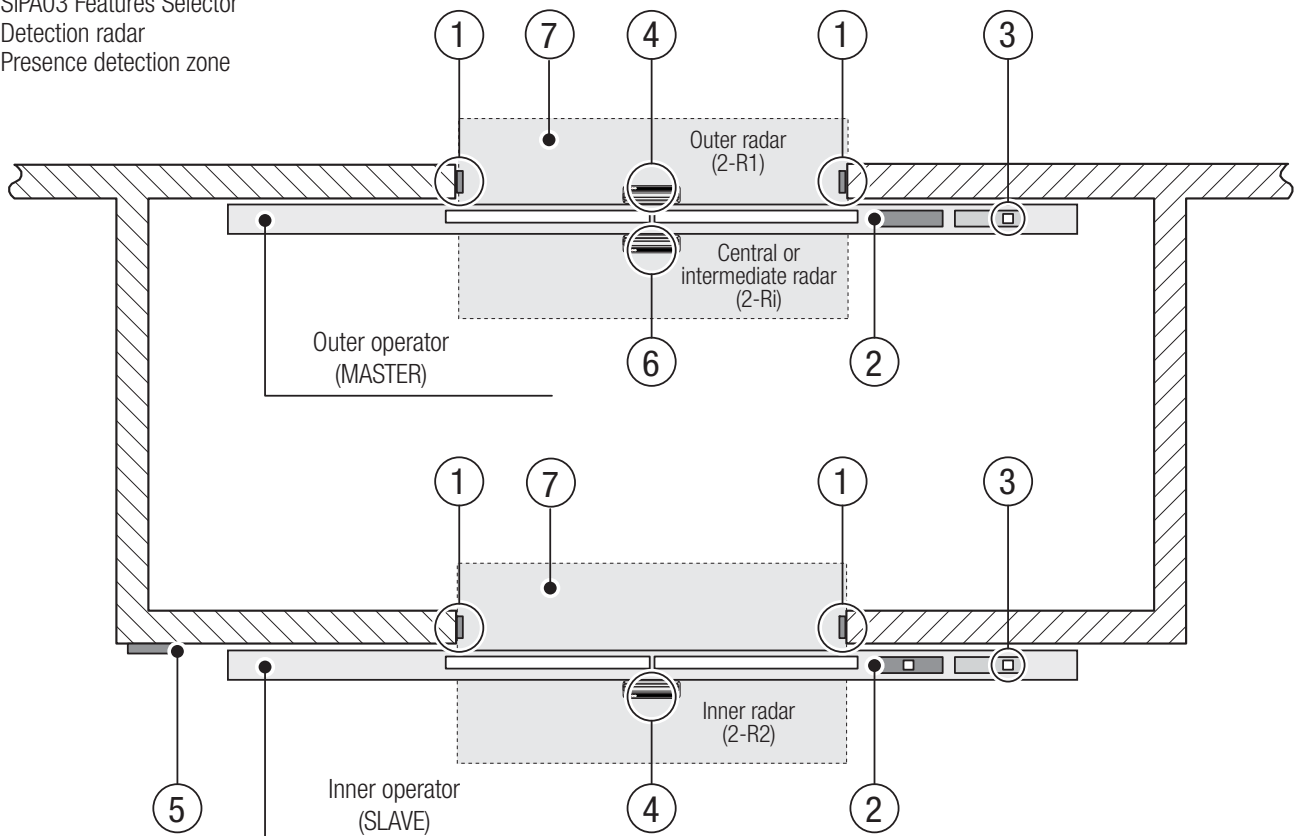

Travel calibration

Calibrate as follows:

- cut off the power supply to both operators;
- connect and set up as described in the paragraph (SPECIFIC CONNECTIONS FOR THE ALTERNATING SYSTEM);
- power up both operators again;
- set DIP switches 2 and 3 to ON on the MASTER board;
- press the reset key on the MASTER board for two seconds;
- set DIP switch 1 to ON on the MASTER board (the SLAVE operator's leaves will fully open until the end rest, then the MASTER operator's leaves will do the same);
- reset DIP switch 1 to OFF;
- send an opening command (from contact 2-R1).

Operation

When one of either radars detects a presence, the operator opens the corresponding door and simultaneously blocks the other:

Sequence of standard operations: outer and inner detection by sensor
opening of^{1st} door / blocks the other door
closing 1st^{door}
opening 2nd^{door}
closing 2nd^{door} / releases the other door

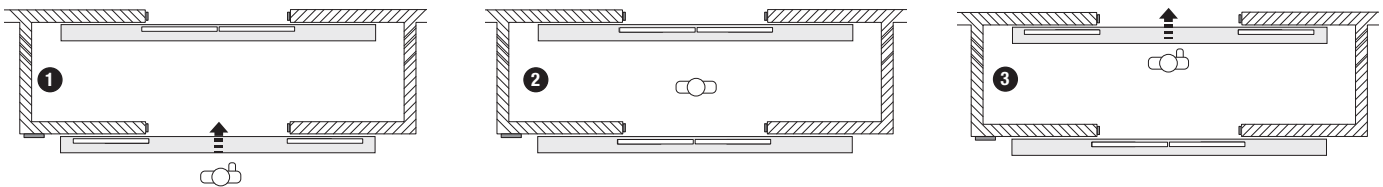

The central (intermediate) sensor connected to terminals **2 - Ri**, detects the presence of people between the two operators, and enables opening of the operator opposite the one that has just opened.

PAIRED SYSTEM (FOR PASSAGE WIDTHS OF LESS THAN 3350 MM)

- 1 Photocells
- 2 ZP11 Board
- 3 001SIPA02 Electroblock
- 4 MR8003 Board
- 5 SIPA03 Features selector

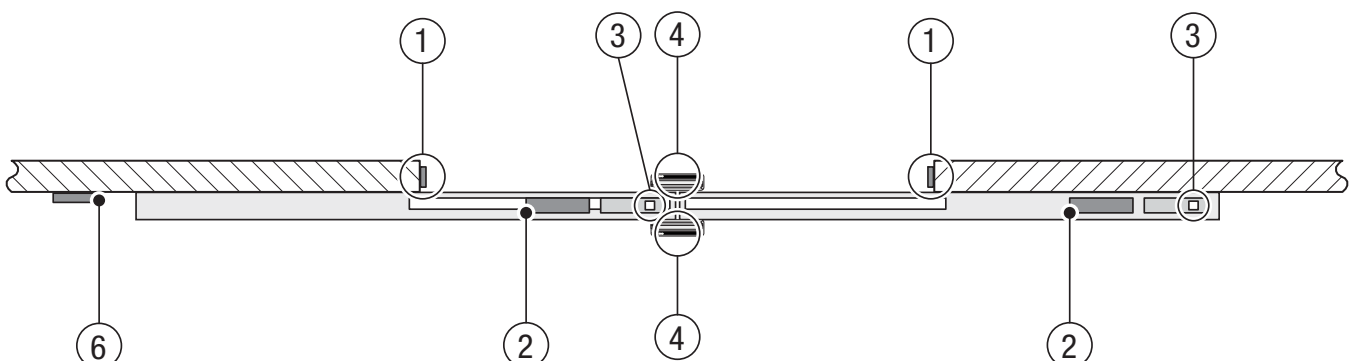

Specific connections connections for the paired system

- Check that DIP-switch 5 on each board is properly set.
 - Connect the boards amongst themselves using the alternating/paired terminal (see diagram).
 - On the board where all of the accessories are connected (photocells and anti-panic included) and possibly the features selector (MASTER) set DIP-switch 2 to ON and DIP-switch 3 to OFF. Adjustments must also be done on the MASTER board.
- On the SLAVE operator, check that DIP-switches 2 and 3 are OFF.
- If contacts 1-2 and 2-C1 on the MASTER board are unused, they must be bridged.

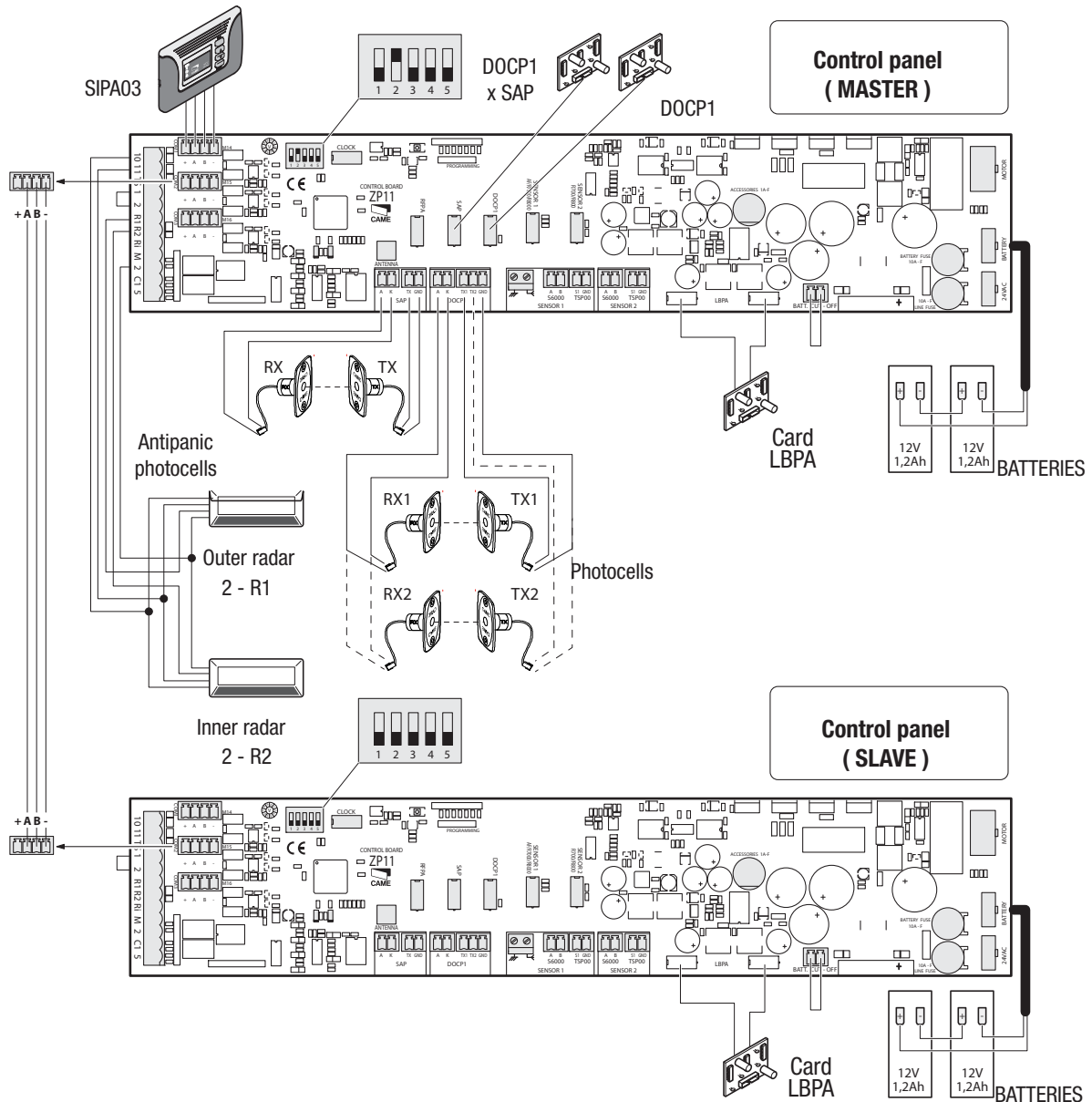

Travel calibration

Calibrate as follows:

- cut off the power supply to both operators;
- connect and set up everything as described in the SPECIFIC CONNECTIONS FOR THE PAIRED SYSTEM paragraph;
- power up both operators again;
- set DIP switch 2 to ON on the MASTER board;
- press the rest key on the MASTER board for two seconds;
- set DIP switch 1 to ON on the MASTER board (the SLAVE operator's leaf will fully open until the end rest. Then the MASTER operator's leaf will do the same);
- reset DIP switch 1 to OFF;
- send an opening command (from contact 2-R1).

Operation

It uses two beams with interconnected control boards as with the alternating feature, but the two operators are controlled by the MASTER board.

TROUBLESHOOTING

| PROBLEM | REFERENCES | POSSIBLE CAUSES |
|---|----------------------------------|--|
| The operator does not open | 1-2-3-4-5-6-10-11-19-20-22-24-26 | 1 - Power supply - missing or inadequate |
| The operator does not close | 4-5-7-8-9-10-11-18-19-22-26 | 2 - Fuses are out-of-order |
| The operator does not open completely | 3-11-15-16-17-19-22-23-24-25-26 | 3 - Initial programming - missing or inadequate |
| The operator does not close completely | 3-11-15-16-17-19-22-23-24-26 | 4 - Wrong selection with the (SIPA03) features selector or (SIPA04) transceiver selector |
| The operator always works at reduced speed | 17-19-22-23-24-25 | 5 - Connections are wrong |
| The operator does not maintain the initial adjustments | 15-16-17-19-22-23-24-25-26 | 6 - Bridge 1-3 is missing |
| The electroblock prevents opening | 5-19-20 | 7 - Contacts 2-C1 have no safety device or are not shortcircuited |
| The photocells do not work | 5-7-8-9-19 | 8 - The safety photocells are not aligned or do not work |
| The operations does not coincide with the feature set on the selector | 5-10-19 | 9 - Photocell feature needs to be selected with the selector |
| The anti-panic feature does not work | 4-12-13-22-23-24-25 | 10 - The motor connection is wrong |
| System is overly noisy | 22-23-24-25 | 11 - Encoder is out of order |
| | | 12 - The (RFPA) anti-panic card is out-of-order |
| | | 13 - The batteries are flat |
| | | 15 - Inadequately adjusted opening and closing slow-downs |
| | | 16 - Inadequately adjusted opening and closing slow-down points |
| | | 17 - Inadequately adjusted opening and closing speeds |
| | | 18 - TCA adjusted excessively |
| | | 19 - The general ZP11 control board is out-of-order |
| | | 20 - The electroblock does not work |
| | | 22 - The is friction between moving and fixed parts - remove causes of contact |
| | | 23 - Towing movement impeded - (between carriages and cables) |
| | | 24 - There may be residuals/objects on the slide rail |
| | | 25 - Inadequately belt tension |
| | | 26 - Align the mechanical stops |

DISMANTLING AND DISPOSAL

 CAME CANCELLI AUTOMATICI S.p.A. employs a certified Environmental Management System at its premises, compliant with the UNI EN ISO 14001 standard to ensure the environment is safeguarded. Please continue safeguarding the environment. At CAME we consider it one of the fundamentals of our operating and market strategies. Simply follow these brief disposal guidelines:

DISPOSING OF THE PACKAGING

The packaging materials (cardboard, plastic, and so on) should be disposed of as solid urban waste, and simply separated from other waste for recycling.

Always make sure you comply with local laws before dismantling and disposing of the product.

DO NOT DISPOSE OF IN NATURE!

DISMANTLING AND DISPOSAL

Our products are made with different materials. Most of these (aluminum, plastic, iron, electrical cables) is classified as solid urban waste. They can be recycled by separating them before dumping at authorized city dumps.

Whereas other components (control boards, batteries, transmitters, and so on) may contain hazardous pollutants.

These must therefore be disposed of by authorized, certified professional services.

Before disposing, it is always advisable to check with the specific laws that apply in your area.

DO NOT DISPOSE OF IN NATURE!

DECLARATION OF CONFORMITY

Declaration CE Came Cancelli Automatici S.p.A. declares that this device conforms to the essential, pertinent requirements provided by directives 2006/42/CE and 2004/108/CE.

An original copy of the declaration of conformity is available on request.

English - Manual code: **FA00323-EN v. 1** - 02/2016 - © Came S.p.A.
The contents of this manual may be changed at any time without prior notice.

CAME
safety&comfort



CAME S.p.A.

Via Martiri Della Libertà, 15

31030 **Dosson di Casier**
Treviso - Italy

📞 (+39) 0422 4940

📠 (+39) 0422 4941

Via Cornia, 1/b - 1/c

33079 **Sesto al Reghena**
Pordenone - Italy

📞 (+39) 0434 698111

📠 (+39) 0434 698434

www.came.com